

SPANISH NUCLEAR INDUSTRY 2021

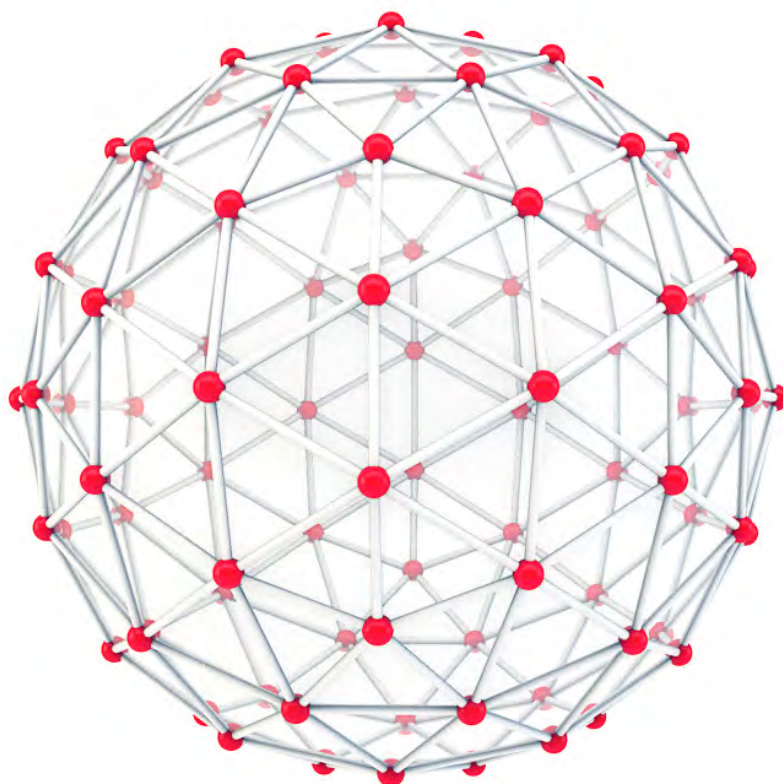



THANK YOU

To all the companies that make this catalogue real.



INDEX

—

06

President's letter

07-09

Introduction

Spanish Nuclear Industry Forum

12-19

Electricity utilities

EDP
ENDESA, S.A.
IBERDROLA, S.A.
NATURGY

22-25

Nuclear Systems Suppliers

GE-Hitachi Westinghouse
Electric Spain

28-39

Nuclear Power Plants

ANAV, Ascó & Vandellós II Nuclear Power Plants
CNAT, Almaraz I & II & Trillo Nuclear Power Plants
Iberdrola, Cofrentes Nuclear Power Plant
Nuclenor, Santa María de Garoña Nuclear Power Plant

42-43

Fuel

ENUSA Industrias Avanzadas, S.A., S.M.E.

46-61

Equipment Goods

CEN Solutions
Coapsa Control, S.L.
Equipos Nucleares, S.A., S.M.E.
Konecranes
Newtesol, S.L.
Nusim, S.A.
Ringo Válvulas, S.L.
Taim Weser, S.A.

64-83

Engineering and Services

Amphos 21
Empresarios Agrupados
Enwesa
GD Energy Services
Geotecnia y Cimientos, S.A.
Grupo Eulen
IDOM Consulting, Engineering, Architecture, S.A.U.
Proinsa, S.A.U.
Tecnatom, S.A.
VIRLAB, Expertise in Vibrations and shocks. Testing Laboratory

86-87

Waste Management and Decommissioning

Enresa

88-89

Web directory



IGNACIO ARALUCE

PRESIDENT OF SPANISH NUCLEAR INDUSTRY FORUM

In generating wealth and employment, the Spanish nuclear industry has leading edge capabilities and exports products, services and high technology to more than 40 countries. Recognised at an international level and with a firm commitment to human factors, as well as research and development, it intervenes in the whole chain of nuclear value. As indicated in this publication, it develops the initial studies, the conceptual design, the construction of reactors, the manufacturing of fuel, engineering for operation and maintenance, the supply of equipment and components, training, the management of waste, dismantling of installations, descontamination or provides support to production.

The recognition and prestige of the Spanish nuclear sector is also reflected in the perfect maintenance and updating of the Spanish nuclear reactors, which operate with maximum guarantees of safety and excellent performance indicators.

It is also the technology that most helps curb climate change by generating more than 33% of emission-free electricity annually.

The capacities, experience and state of the art technology of the sector, applied to the services and products that it provides to the Spanish nuclear power plants, lead to load factors, operation or availability of more than 90%. Year after year, this figure makes nuclear energy the source that produces the most electricity and operates the most hours.

In Spain, the nuclear power plants are leaders in production. They generate more than 22% of the electricity that we consume and help to decrease contaminating emissions to the atmosphere. Guarantee of supply and no CO₂ emissions are two of the reasons why many countries seek to maintain and develop this technology and in doing this, join forces with the Spanish nuclear sector.

Nuclear energy still has a big pull worldwide. Currently there is 443 reactors in a position to operate and 52 units in construction around the world, according to the United Nations' International Atomic Energy Agency (IAEA). Together with the hundreds of planned reactors these data push the companies in the Spanish nuclear sector to expand internationally and to open new markets. Foro Nuclear is involved in this task of promoting the nuclear business and showcasing the capacities of the Spanish nuclear industry by supporting the presence of our industry on the exterior by participating in congresses, business missions, exhibitions and meetings in collaboration with Spanish and international institutions.

This publication, available in Spanish and English, and issued since 2008 in collaboration with ICEX, includes the capacities and services that the Spanish nuclear companies offer, their business objectives and activities and references. A show of how well our sector is doing at the technological forefront with an ever-growing consolidated international presence.



THE SPANISH NUCLEAR SECTOR

For the tenth consecutive year, nuclear power in Spain is the first source of electric production. Spanish nuclear power plants generated more than 22% of electricity in 2020.

In Spain, nuclear energy has represented approximately 20% of the total production of electricity in recent years. On a world scale, nuclear generation represents almost 11% with 443 reactors in a position to operate in 31 countries and 52 new reactors in construction in 20 countries.

These data have meant that a large number of Spanish companies have focused their activity in the nuclear sector, based on the experience and thanks of their participation in the development of the Spanish nuclear programme since its beginnings and are present in the whole chain of value.

All of this industrial structure has evolved with the circumstances of each moment, incorporating new technologies adapted to current needs and requisites and making it possible that Spanish companies are present today in nuclear projects in more than 40 countries, in four of the five continents.

The Spanish nuclear industry also participates in international research and development projects for advanced nuclear reactors, in programmes based on nuclear fusion, such as the ITER International Project and in programmes related to high energy physics.

The companies that work in the nuclear sector are grouped in this catalogue according to the activity that they carry out.

The electrical companies focus their main activity on the production, transportation, distribution and commercialisation of electricity. The objective of these companies is to work permanently towards excellence in the management of nuclear power plants, with a commitment to continue to produce in a safe and reliable way and promoting growth in their areas of influence both from the social, economic and environmental point of view.

Since the construction of the first nuclear power plant they have extended their actions to the study of the optimization of the performance, maintenance, management of improvements in equipment and procedures, management of the fuel cycle and the development of new reactors.

The Spanish electrical companies are capable of participating in an efficient manner in international markets undergoing a process of growing integration, globalisation and increase in competition.

The international suppliers of nuclear systems provided the first "key in hand" nuclear power plants in Spain and the steam generation systems for the nuclear power plants that were built after that. This was due to the fact that, at the beginning of the Spanish nuclear programme, the decision was made not to constitute a company of systems linked by license to a foreign supplier, which would have meant having to choose a single type of reactor.



The suppliers of electrical systems currently provide support services to nuclear sites in operation and maintenance in more than 20 countries, such as for example, Germany, Belgium, Brazil, Bulgaria, China, Slovakia, Slovenia, United States, Finland, France, India, Japan, Mexico, United Kingdom, South Africa, Sweden, Taiwan, etc.

These companies work through agreements with Spanish companies with which they have developed strong technological links. This has led to a framework of mutual benefit, through which the Spanish industry has been able to participate in the development of nuclear projects all over the world.

The design, manufacture and supply of fuel to Spanish and international nuclear power plants is made by the public capital company ENUSA Industrias Avanzadas and is responsible for the supply of raw materials and their processing right through to the final elaboration of the product. It is the owner and operator of the fuel elements factory in Juzbado (Salamanca), one of the most innovative in Europe which, since the start of its operation in 1985, has manufactured more than 25,000 fuel elements for both Spanish and foreign nuclear power plants.

The manufacture of capital equipment is made by Spanish companies who cover the production of main equipment to turbine alternators, valves, cranes, piping, boilers or equipment for handling the storage

of fuel for both Spanish and foreign nuclear power plants, with a recognized level of quality. At present more than 80% of their annual production is exported.

At present, the whole portfolio of orders for the supply of large components as well as a high percentage of the rest of components of this group of companies is for exports.

The Spanish engineering and services companies have created an important engineering capacity for nuclear power plants, providing support in the management of the construction of new plants and in the operation and maintenance of the plants in operation, with a very diversified activity in which they export more than 60% of their annual production and in some cases up to 100%.

These companies have developed very specialised services such as the supply of simulators, training programmes for operators, in service inspection and the development of support and improvement systems in production. Their clients include all of the Spanish nuclear companies and a large number of foreign entities.

Some of these companies have laboratories for radiological analysis which offer an integral service that responds to all the needs of the sector and which are focused on the efficient and sustainable management of their activities.

Radwaste management in Spain is carried out by the National Radwaste Company, ENRESA. It is a public company and is an important international reference and example as its activities are studied and monitored by more than 15 countries around the world who have visited its site.

Very low, low and medium activity radwaste from nuclear sites, hospitals research centres and industry is managed in the Storage Centre in El Cabril, located in the province of Cordoba.

The fuel used in the nuclear power plants is kept in the onsite pools or in some cases, such as Trillo, Ascó, Almaraz or José Cabrera (in dismantling), in the Individual Temporary Storage Facilities, located onsite, until the future of the Centralised Temporary Storage (ATC) is clarified.

Among its activities it is also responsible for decommissioning nuclear and radioactive sites and was a pioneer in the decommissioning of the nuclear power plants of Vandellós I and José Cabrera.

Spanish Nuclear Industry Forum (Foro Nuclear) is a non-profit association which defends the Spanish nuclear sector and the continuity of the nuclear power plants and covers all of these companies and supports them in all the activities that they require.

Through their four phases of action, Support to the Industry, Technical Support, Communication and Education and Training it attends to the needs of the companies in the Spanish nuclear sector, at both a national and an international level.

In the area of Support to the Industry, Foro Nuclear coordinates the activities of the industry in different scenes, such as the participation in exhibitions with grouped pavilions, the organisation of business meetings among companies from different countries, the coordination of technical workshops in events of interest, etc.

For all of these activities it has the support of both national and international entities and institutions which gives it a greater diffusion and the possibility of reaching other companies that are not members of the Association.

Thanks to a collaboration agreement signed with ICEX Spain, Trade and Investment, Foro Nuclear is recognised as an agent responsible for providing services, in the name

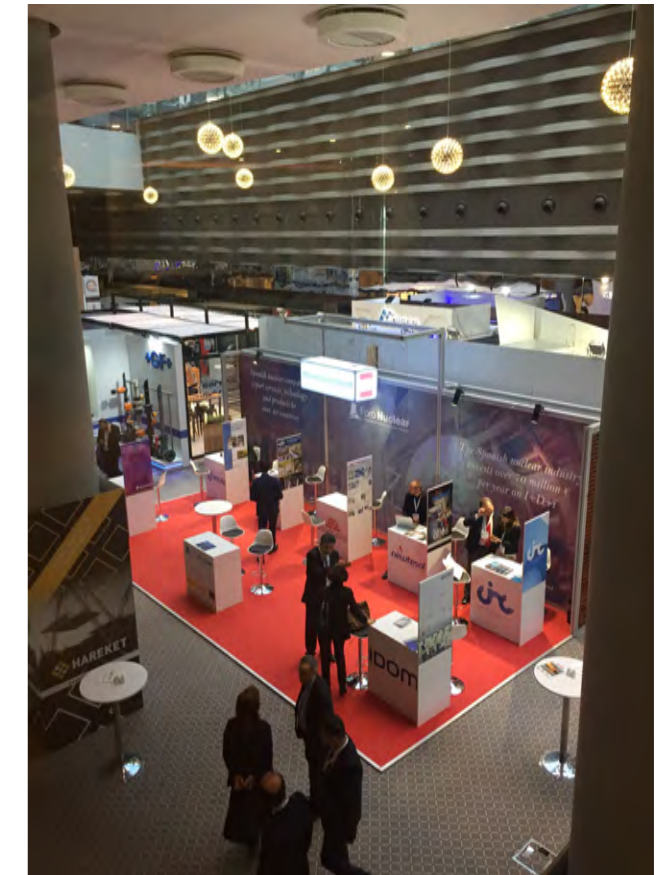

and representation of the entity, for the internationalisation of the nuclear sector companies, in the area of the management of aid relating to the promotion of internationalisation.

Through specific agreements with the commercial offices in Spain of those countries that are of interest for the companies in the nuclear sector, Foro Nuclear organises bilateral business meetings which make it possible to know the capacities of the participating companies and open up the possibility for collaboration among them, both in the countries that organise the meeting and in third countries.

The figures of the activity of our nuclear industry and the degree of internationalisation of their companies are the best proof of the competitiveness of the sector and the capacity of our professionals. At present the nuclear sector is a consolidated, prestigious industry that generates wealth and employment.

The aim of the catalogue of the Spanish nuclear industry is to reflect the reality of an open and dynamic sector in a growing international market.





ELECTRICITY UTILITIES

—
EDP
ENDESA, S.A.
IBERDROLA, S.A.
NATURGY

12-19

—
The Spanish electric utilities constantly work towards excellence in the management of nuclear power plants with a strong commitment to enabling long term production in a safe way.



EDP

Headquarters
Plaza del Fresno, 2
33007 Oviedo (Asturias)
Tel.: +34 902 830 100

C/ Serrano Galvache, 56
Edificio Encina
Centro empresarial Parque Norte, 2º
28033 Madrid
Tel.: +34 902 830 100



C/ General Concha, 20
48010 Bilbao (Vizcaya)
Tel.: +34 944 035 700

In Spain, EDP is formed by a group of companies intended for electricity production and distribution, also focused on commercialization of electric power, natural gas and energetic services.

It takes part of the energetic group EDP, a worldwide leader and one of the main traders in the Iberian Peninsula. The company is present in 20 countries with a total capacity of 24.9 GW, with a renewable power generation of 74%. It is the fourth largest wind energy operator in the world.

The EDP Group has more than 9 million clients and 12,000 employees of 44 different nationalities.

EDP is leading the energy transition to create better value with an accelerated and sustainable growth. It's a benchmark in ESG recognized by the main institutions with a future-proofed company and a strong social activity through its Foundation.



ELECTRICAL GENERATION

In Spain, EDP has a diversified generator park which stands out for its efficiency, high availability and operation flexibility with a 97% of generation capacity with environmental certification. Its participation in the Trillo Nuclear Power Plant allows EDP to have first level nuclear experience.



Data 2020	Production (GWh)	Power (MW)
Hydraulic	677	419
Thermal energy	2,431	1,250
Combined Cycle	4,107	854*
Nuclear	1,196	156
Aeolic	4,346	2,1375
Cogeneration	73	38
	12,830	4,941

* Not including the Castellon combined cycle whose sale to Total was closed in November

2020 Economic Data (million €)	EDP In Spain	EDP Renewables	EDP Group
EBITDA	308.6	1,655	3,950
Net Profit	105.2	556	801
Number of employees	987	1,735	12,180

ELECTRICAL DISTRIBUTION

E-REDES Electrical Distribution leads the quality of electricity supply in Spain and stands out for its efficiency and its digitization process of the network.



2020 Electrical distribution (Without Viesgo)

Power supply points	671,576
Electrical energy distributed (GWh)	8,262
SAIDI (System Average Interruption Duration Index) (min)	15

In December, the acquisition of Viesgo was closed, which implies duplicating networks in Spain until reaching a total of 1,340,000 supply points.

In addition to Asturias, where it's the leading operator, it has consolidated electricity distribution networks in Madrid, Valencia, Alicante, Barcelona, Huesca and Zaragoza. Besides all these locations it's now added 31,300 kilometers of Viesgo extended across the north of the country in the regions of Cantabria, Galicia, Asturias and Castilla y León.

COMMERCIALIZATION

In the Commercial area, marked by the sale of B2C consumed in December, the commercialized electricity reached 10,790 GWh and natural gas reached 7,414 GWh.



RENEWABLES

EDP Renewables is the fourth global operator of wind energy with an installed capacity of 12,168 MW. It's based in Spain where it reaches 2,137 MW of installed capacity. It's functional in 12 countries and in 2020 generated 28,537 GWh, of which 4,346 GWh corresponds to Spain. Development of three lines of activity: onshore wind, offshore wind and solar energy. Operational excellence and commitment with local communities and society.



SERVICES

Innovation in solutions for customers with new energy services such as distributed solar energy, storage, energy efficiency and electric mobility. Establishment of business partnerships to improve the scale, reach and competitiveness.



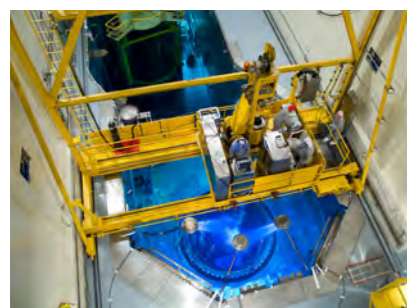

Endesa was founded in 1944 and is a leading company in the electricity sector in Spain and the second largest in the electricity market in Portugal. The company belongs to the Enel multinational energy group, it employs about 10,000 people and serves 10.4 million customers.

ENDESA's main business activity is the generation, distribution and sale of electricity. The Company is also a major operator in the natural gas market and provides other services related to energy.

COMMITMENT TO DECARBONISATION

ENDESA is aware of its role and as a benchmark agent in the energy sector in Spain, one of its priorities is to gradually reduce greenhouse gas (GHG) emissions associated with the generation of electricity by increasing the role played by renewable energies and optimising the management of traditional technologies.

In the short term for the 2021-2023 period, Endesa has announced an acceleration along the path to decarbonisation and Energy Transition based on a significant increase in investment in renewable energies and the digitisation of its network, as well as in the electrification of domestic demand and of sectors such as industry and transport.

Endesa will increase the volume of its investments by 25% for these three years compared to the 2020-2022 strategic plan, and this is expected to reach 7,900 million euros. Of this figure, 3,300 million euros will be earmarked to increase Endesa's energy generation assets, a figure that is 20% higher than in the previous plan.

With this investment, the company will reach 11,500 MW of solar, wind and hydraulic energy by the end of 2023 and enable 89% of Endesa's energy production in the Iberian Peninsula at the end of 2023 to be free of CO2 emissions.

This acceleration of investment in renewable energy will enable 3,900 MW of power to be connected, of which 3,000 MW will be photovoltaic plots and the rest (900 MW) will come from wind. The new power will far exceed the reduction of 2,500 MW in the Endesa generation mix as a result of the closure of coal-fired power plants in the Iberian Peninsula in 2021.

The second major investment included in the new plan is that destined to the distribution network, which will see an increase of 30% over the previous plan, with a total of 2,600 million euros for network digitisation and improved supply quality. This investment is expected to reduce both the number of power cuts and their duration by 23% and 27% respectively.

SERVICES, PRODUCTS AND TECHNOLOGY AVAILABLE

The main markets for Endesa's activities in the electricity and gas business are Spain, Portugal and Morocco. To a lesser extent, it markets electricity and gas in other European markets, as well as other value added products and services (PSVA in Spanish) related to its core business.

In the generation activity, Endesa has a diversified energy mix with nuclear energy as the main technology with a production of 25,839 GWh, out of a total annual production of 56,269 GWh in 2020.

Capacity (MW)	22,465
Production (GWh)	56,269
Sales (GWh)	89,639
Nº of customers	10,420,000
Revenue	17,579 million €
Gross operating profit (EBITDA)	3,783 million €
Operating Profit (EBIT)	1,886 million €
Net Profit	1,394 million €
Workforce	9,591 employees
Distributed energy (GWh)	124,658

*Figures at 31 December 2020

Endesa's installed power in Spain totalled 22,465 MW in December 2020 compared to 24,231 MW for the previous year after the closure and disconnection from the network of the thermal power plants in Andorra (Teruel) and Compostilla (León). This means that Endesa's generation plants, located in Spain, Portugal and Morocco, represent an installed capacity of 7,825 MW of renewable energy (4,793 MW of hydraulic, 2,423 MW of wind and 609 MW of solar power), 5,681 MW of Combined Cycles, 5,506 MW of classic thermal, and 3,453 MW of nuclear thermal power.

- In the Distribution activity, Endesa transmits electricity to the points of consumption and supplies almost 22 million people in Spanish territory, via 315,365 km of distribution and transport networks and 124,658 GWh of distributed energy.

- In terms of the Marketing of electricity, gas and value added products and services (PSVA), by 2020, net electricity sales amounted to 80,772 GWh and the customer portfolio in the electricity market consisted of 10.4 million supply points. The total volume of gas marketed in 2020 amounted to 70,045 GWh and the customer portfolio in the conventional natural gas market consisted of 1.6 million supply points.

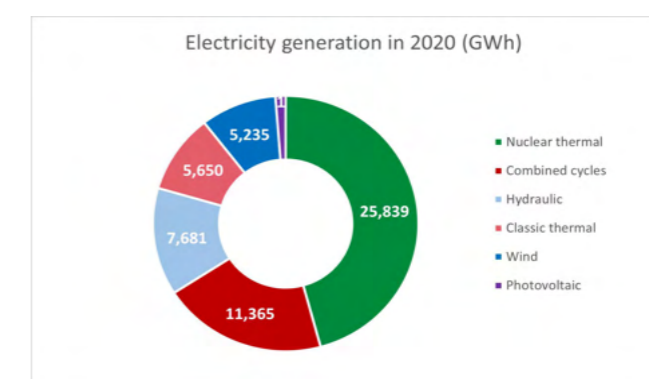

ENDESA AND NUCLEAR PRODUCTION

Endesa is the largest producer of nuclear energy in Spain, with 47% of nuclear power installed through its shareholding in a number of power plants amounting to 3,453 MW.

Endesa is continuously searching for excellence in the management of its nuclear power plants and in 2020, under difficult conditions due to the Pandemic,

The load factor for these was 88.6%, in line with the figures for 2019. The company is committed to the long-term safe and reliable operation of nuclear assets as may be seen in its nuclear policy that was adopted in February 2011. This commitment also extends to the environment in which plants are located, both socially and environmentally, as a drive for economic growth.

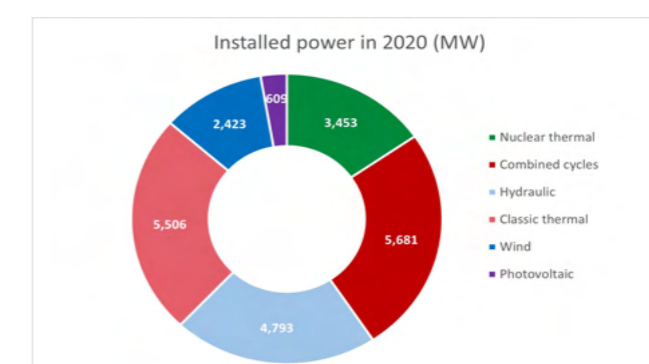

Nuclear Power Plants		% ENDESA	Participation ENDESA (MW)
Ascó I	1,033	100	1,033
Ascó II	1,027	85	873
Vandellós II	1,087	72	783
Almaraz I	1,049	36	378
Almaraz II	1,044	36	376
Trillo	1,066	1	10.7
Cofrentes	1,092	0	0
Total Nuclear	7,399	47	3,453





IBERDROLA, S.A.

Headquarters
Plaza Euskadi, 5
48009 Bilbao (Vizcaya)
Tel.: +34 944 151 411

Iberdrola Generación Nuclear
C/ Tomás Redondo, 1
28033 Madrid
Tel.: +34 915 776 500



Iberdrola is a private global company with experience forged over the span of more than hundred seventy years of history at the service of energy development, supply guarantee, quality and innovation

Iberdrola owns a balanced, efficient and well diversified grid, guaranteeing its response capacity in any energy related matter.

BUSINESS OBJECTIVE

The company has taken a decisive and pioneer bet to use cleaner generation technologies, fight against climate change and respect towards the environment, becoming world wide leader in wind power. After last quarter of 2020, renewable business has got 34,923 MW of installed capacity around the world.

Fighting against climate change and in favor of sustainable development is one of the strongest commitments of Iberdrola, establishing as environmental objective to reduce the CO₂ emissions below 150 gr per kWh in 2030, that is, 50% below the specific emissions released by the company in 2007 and be carbon neutral by 2050.



SERVICES, PRODUCTS AND TECHNOLOGY AVAILABLE

Main activities of Iberdrola consist of electricity production through renewable and conventional sources, trade in electricity and gas in wholesale markets, transmission and distribution of electricity, marketing of electricity and other activities mostly connected to the energy sector.

From the whole installed capacity, nearly 63% corresponds to renewable energies; 29% to combined-cycle gas plants; 6% to nuclear; and the remaining 2% to cogeneration.



Countries where it has activity	Around 40
Users	34 millions
Staff	37,127 employees

Iberdrola's 43% of nuclear capacity in Spain



IBERDROLA SHARE IN THE SPANISH NPP'S

NPP	CAPACITY (MWe)	Share IBERDROLA	Capacity IBERDROLA (MWe)
Cofrentes	1092	100%	1092
Almaraz I y II	2094	53%	1103
Trillo	1067	49%	523
Vandellós II	1087	28%	304
Ascó II	1027	15%	154
			3177

NUCLEAR ENERGY IN IBERDROLA

From the whole electricity generated by Iberdrola in Spain, more than 40% comes from nuclear plants, with an installed capacity of 3,177 MW. For Iberdrola, the safety of its nuclear plants is the prime objective over other aspects as economics, production or compliance of schedule. Likewise, Iberdrola is committed to generate electricity from nuclear plants in a respectful way with environment, making rational use of natural resources, maintaining the best quality standards and excellence levels, and continuously carrying out the modernization of its plants according to the state of the art in this field

OUTSTANDING NATIONAL AND INTERNATIONAL ACTIVITIES

Iberdrola group is a global energy leader, the largest wind power producer and one of the largest electricity companies by market capitalization in the world at the end of 2020. Iberdrola leads the energy transition towards a sustainable model through large investments in renewable energies, networks smart devices, large-scale energy storage and digital transformation to offer the most advanced products and services for its customers.

Iberdrola firmly believes that the transition to a carbon neutral economy by 2050 is technologically possible, economically viable and socially necessary. The decarbonization of the economy is a great opportunity to create wealth, generate employment and

improve the state of the planet and the health of people. For this reason, the group is committed to leading the energy transition, a path that it started 20 years ago and which has led it to invest € 120,000 million since then, to which it will add another € 75,000 million between 2020 and 2025.

Iberdrola faces this scenario by relying on the strategic pillars that have been the basis of its growth: increasing geographic diversification towards countries with solid credit ratings and ambitious climate policies, maximizing the operational excellence of its plants on a continuous basis, optimizing the portfolio towards sustainability, environmental and financial and promoting innovation and digitalization.

Headquarters
Avda. de San Luis, 77
28033 Madrid

Office in Barcelona
Plaça del Gas, 1
08003 Barcelona
Tel.: +34 934 025 100



Naturgy is an multinational energy group operating in more than 20 countries where it serves more than 16 million customers with a rated output of 15.3 GW. The basis of its business are in the regulated, liberalised gas and electricity markets.

The company is listed on the four Spanish stock exchanges via the continuous market and forms part of the select Ibex 35 index.

This Spanish multinational participates across the entire energy value chain, from generation and distribution to the commercialisation of natural gas and electricity. Its generation mix is

diversified and includes renewable sources, combined-cycles, hydraulics, coal and nuclear.

Internationally, Naturgy has a capacity of 3.2 GW distributed in 2.4 GW from combined cycle plants (Mexico), 0.2 GW from fuel (Dominican Republic), 0.1 GW from hydroelectric (Costa Rica and Panama) and 0.6 GW from renewable energy (Mexico, Australia and Brazil).

Naturgy is also the leading operator in the Atlantic and Mediterranean basins, managing an LNG supply portfolio of approximately 28 bcm.



Data 2020

Net turnover	15,345 million €
Net profit	872 million €
Consolidated EBITDA	3,714 million €
Workforce	9,580 employees

OUTSTANDING NATIONAL AND INTERNATIONAL ACTIVITIES

Naturgy promotes best practices in energy infrastructure management, aligning its activities with its concern for the environment, the development of low-emission economies and sustainability. Moreover, as an energy operator, it seeks to achieve progress in the use of increasingly efficient and less polluting energies and is committed to attaining enhanced air quality for our urban environments.

In the electricity generation business, the group's strategy focuses on having a balanced, competitive and environment-friendly generation mix, in keeping with the objectives and commitments of the COP 21 with regard to global warming and consolidation of its presence as one of the chief operators of the Spanish electricity sector.

Naturgy's electricity generation capacity in Spain stands at 15.2 GW and is based on a balanced, competitive and environmentally-friendly generation mix with significant contributions from five technologies: 7.4 GW from combined cycle power plants, 2 GW from hydropower, 2 GW from renewables and 0.6 GW from nuclear.

Regarding nuclear power generation, the company participates in the Almaraz (I and II) and Trillo nuclear power plants, with a percentage of 11.3% and 34.5%, respectively.

International Presence



- America**
Argentina, Brazil, Chile, Costa Rica, Dominican Republic, Mexico, Panama, Puerto Rico, United States
- Europe**
Spain, France, Ireland, Portugal, United Kingdom
- Rest of Europe**
LNG/NG marketing; Marketing of electricity; Regasification Montoir.
- Africa**
Algeria, Morocco
- Spain**
Exploration, transport, distribution and marketing of gas and electricity; Generation combined cycle, nuclear, hydropower, thermal, cogeneration, mini hydropower and wind.
- Asia**
China, India, Oman, Pakistan, Singapore, South Korea, Taiwan
- Oceania**
Australia
- Africa**
LNG/NG procurement and infrastructure; Gas pipeline Magreb-Europe and Medgaz.
- Rest of Europe**
LNG/NG procurement, infrastructure and marketing (Qaihat liquefaction plant).

The group's generation business outside Spain is managed by its subsidiary Global Power Generation (GPG), which groups together all the assets and holdings in international generation with a rated output that is currently 3,500 MW and projects awarded for more than 600 MW.





NUCLEAR SYSTEMS SUPPLIERS

—

GE-Hitachi
Westinghouse Electric Spain

22-25

—

Nuclear systems suppliers provide support and maintenance services to nuclear sites in operation across more than 20 countries.



GE-HITACHI

C/ Osiris, 11-15
28037 Madrid
Tel.: +34 915 870 500



GEH is a world-leading provider of advanced reactors and nuclear services. Established in June 2007, GEH is a global nuclear alliance created by GE and Hitachi to serve the global nuclear industry. The nuclear alliance executes a single, strategic vision to create a broader portfolio of solutions, expanding its capabilities for new reactor and service opportunities. The alliance offers customers around the world the technological leadership required to effectively enhance reactor performance, power output and safety.

BUSINESS OBJECTIVE

GEH offers customers innovative solutions that take nuclear energy the smart choice for a cleaner and more secure energy future. GEH is committed to serving the needs of customers, communities and the environment with a balanced portfolio of advanced technologies, trusted services and global energy experience for the world's growing energy needs.

SERVICES, PRODUCTS AND TECHNOLOGIES AVAILABLE

The GE and Hitachi alliance is recognized as the world's foremost developer of boiling water reactors, robust fuel cycle products and highly valued nuclear plant services. Beginning in the 1950s, GE developed breakthrough light water technology with the Boiling Water Reactor (BWR). Since that time, GE has developed nine evolutions of BWR technology including the ABWR and the ESBWR., as well as BWRX-300, within the segment of Small Modular Reactors and Natrium™ which is being developed in collaboration with TerraPower.

NUCLEAR PLANT PROJECTS Advanced Boiling Water Reactor (ABWR)

The ABWR is the world's first and only Generation III nuclear plant design in operation today, providing the benefit of a combined 25 reactor-years of operational experience. GEH's first ABWR began commercial operation at Kashiwazaki-Kariwa in Japan, in 1996. The ABWR is licensed in the U.S., Japan, UK and Taiwan.

Economic and Simplified Boiling Water Reactor (ESBWR)

The ESBWR is a GEH-designed Gen III+ reactor already licensed in U.S. by the NRC. This simplified design provides improved safety, excellent economics, better plant security, a broad seismic design envelope and operational flexibility that increase plant availability. ESBWR employs passive safety design features. The reactor can cool itself for more than seven days with no on-site or off-site AC power or operator action, uses approximately 25 percent fewer pumps and mechanical drives than reactors with active

safety systems and offers the lowest projected operating, maintenance and staffing costs in the nuclear industry on a per-kilowatt basis.

BWRX-300
BWRX-300 is the tenth evolution of the GE BWR designs on a reduced scale of the ESBWR. With 90% smaller volume, its main goal is to offer a major source of power generation able to compete with any other source in Capital Costs. It is design to operate in load following and not only for electricity production, but also for other industrial applications such as hydrogen generation. Currently it is being licensed in US and Canada and will be in operation by 2028.

NATRIUM™
This is a Generation IV design being developed jointly by GEH and TerraPower, based on previous concepts provided by the two companies, PRISM and Traveling Wave Reactor (TWR) in both cases, Sodium Fast Reactors (SFRs)

GLOBAL NUCLEAR FUEL (GNF)
GNF is a world-leading supplier of boiling water reactor fuel, including uranium dioxide and MOX fuel and fuel-related engineering services. GNF operates primarily through Global Nuclear Fuel-Americas, LLC in Wilmington, N.C., and Global Nuclear Fuel-Japan Co. Ltd. in Kurihama, Japan. GNF continues to strategically expand the nuclear fuel cycle by offering customers an extensive portfolio, including Accident Tolerant Fuel designed to stand on severe accident events.

GE Hitachi Nuclear Energy (GEH) President and CEO	Wilmington, NC, USA Jay Wileman
Global Nuclear Fuel (GNF) President and CEO	Wilmington, NC, USA Jay Wileman
Other USA office locations	San Jose, CA; Vallecitos, CA; Morris, IL and Filadelfia, PA.
Other European office locations	Madrid, Zurich, Stockholm

NUCLEAR PLANT SERVICES
As nuclear plants get older and worldwide demand for cleaner energy increases, GEH offers a wide range of valuable services that can improve performance, increase power output and extend plant life. GEH provides the technical leadership and experience for all operational and expansion requirements for BWR and PWR reactors.

PERFORMANCE ENHANCEMENT PROGRAMS
Advanced products and services improving performance and safety, such as Plant Upgrading and Optimization Programs, Lifetime Management, New Instrumentation and Control Platforms and Digital Solutions.

DECOMMISSIONING AND DISMANTLING (D&D)
On the D&D segment, GEH offers solutions in the field of emerging cutting tools, advanced imagery technologies, the latest radiation detection devices and brilliant machines such as autonomous & sorting robots to assess what is possible. Solutions that deliver significant improvement to resolve the biggest issues identified in the market: schedule uncertainty and cost risk.

ACTIVITIES AND REFERENCES
Although GEH has no production centers in Spain, GE has based its strategy on alliances with national partners with whom it has developed strong technology links. This has led to a framework of mutual benefits through which the Spanish industry has been able to participate with GEH many projects throughout the world. The alliances with the following companies are particularly noteworthy:

Empresarios Agrupados has collaborated with GEH in proposals and projects for new plants in several countries, with a wide range of scopes and has been the main project engineering firm for the Cofrentes and Valdecaballeros plants. They also participated in the certification efforts for the new ABWR and ESBWR designs.

As regard nuclear fuel, links with **ENUSA** date back to 1974 and since that time some 10,000 GEH design fuel assemblies have been manufactured for 13 BWR reactors in Europe. Since 1996, GEH has been commercializing Fuel and associated services for Europe through the Spanish company GENUUSA, held jointly by GNFA and ENUSA.

In the area of Reactor Components, **ENSA** has supplied several different items of equipment for the Lungmen ABWR project and in the near future will supply reactor vessels and fuel racks for the new ESBWR designs. It has also manufactured replacement components for delivery to operating plants.

Since 1992, GE has had a Cooperation Agreement with **Tecnatom**, through which the two companies have jointly developed non-destructive testing equipment and have participated in Inspection Services in more than 25 nuclear plants worldwide and in the design of Man-Machine interfaces for certain new reactor designs.

This high degree of participation by the national nuclear industry at world level should be valued especially in view of the fact that GE has access to a wide range of partners and suppliers on the five continents. This is clear indication of the capacities and competitiveness of the sector, which will be strengthened in future projects for new reactors across the world, some already underway.



C/ Estébanez Calderón, 3-5. 1º
28020 Madrid
Tel.: +34 912 106 410



SERVICES, PRODUCTS AND TECHNOLOGY AVAILABLE

Westinghouse's product lines are as follows:

ENGINEERING SERVICES

Westinghouse provides different types of solutions and services to practically all reactors in operation. It offers a compromise of safe and efficient operation of nuclear power plants throughout the world.

Some of the services it provides are:

- Reactor-related engineering, such as support to systems operation, safety evaluations, accident analysis or power uprates.
- BOP engineering.

MANUFACTURING & COMPONENTS

Westinghouse's factories and spare parts supplies have been consolidated in a single business unit in order to cover the following processes:

- Design, supply and replacement of nuclear components.
- Supply of spare parts.

Several Spanish companies have purchased Westinghouse's technology while at the same time becoming its associates both in Spain and in other European countries. Among them are ENUSA, ENSA and TECNATOM.

ORGANIZATION

Westinghouse is worldly organized through Business Units: Plant Solutions: NPP (New Power Plants), D&D Solutions and Government Services. Operating Plant Services: NFEP (Nuclear Fuel, Engineering and Parts) and OMS (Outage and Maintenance Services) and Global Operations Services. Westinghouse is divided in three regions (America, EMEA (Europe/Middle-East and Africa) and Asia). This way it fulfills its vision of developing locally applied global solutions.



Westinghouse Electric Company is the world's leading supplier of safe and innovative nuclear technology. We provide our utility customers around the world with the most reliable, dependable nuclear power plants, nuclear fuel, plant automation and operating plant products and services. We are driven by our powerful history and experience, ground-breaking ideas, focus on safety and sustainability, and our strong team of approximately 8,765 employees around the world.

Westinghouse's presence in Spain began in the mid-sixties with the supply, under a turnkey contract, of the José Cabrera Nuclear Power Plant to the electric company Unión Eléctrica Madrileña. Already in 1972 Westinghouse had its own office in Madrid, and since then its presence has been permanent and active by offering services to the Spanish nuclear power plants.

In 2001, Westinghouse acquired Initec's nuclear division, thus expanding its business in the country. Nowadays, Westinghouse has 244 employees in Spain across three locations: Madrid, Vandellós and Hospitalet del Infante (Tarragona).

Turnover in Spain	62 million €
% had a direct or industrial relationship with exports	50%
% of the volume of sales comes of the nuclear sector	100%
Countries of activity	12
Nuclear power plants that Westinghouse Corporate gives service	20-30 South > 300 worldwide
Westinghouse Corporate staff	8,765 employees

FUEL

Westinghouse provides nuclear fuel and all the engineering services related to operating nuclear power plants. From its factories in the United States, Sweden, United Kingdom and Japan, and its agreement with ENUSA, Westinghouse is capable of providing fuel to power plants of all commercial technologies in any country.

Furthermore, Westinghouse carries out all the necessary fuel inspection and repair services for their operation.

FIELD SERVICES & MODIFICATIONS

Regarding Outage & Maintenance services, such as reactor services, Fuel Handling or inspection, all of them are done locally in Spain. For very specialized services, our local team is supported by European or American organizations.

Also, this business unit has been unified with plant modifications including Design Modifications and its associated engineering.

INSTRUMENTATION & CONTROL

Westinghouse owns technology and instrumentation and control products for both protection and plant reactor control systems. Additionally, Westinghouse designs, supplies and installs instrumentation and control systems for the rest of the plant. The effort currently being made by plants towards digitalization of control systems is especially significant. In this respect, Westinghouse stands out as a pioneer with its Ovation platform.

DECOMMISSIONING & DECONTAMINATION (D&D)

Based on the successful experience of Westinghouse Electric Spain in Decommissioning Plans; Main Engineering; Site Remediation; Waste Storage Design: High, Medium and Low level; along with engineering support and Vessel and Internal segmentation capabilities, Westinghouse provides solutions for a wide range of Decommissioning, Dismantling, Remediation and Waste Management Projects.

More than 30 years of national and international experience endorsed the new D&D business unit being remarkable: El Cabril and Radiana Waste Repository Design, Zorita and Barsebäck Internal and Vessel segmentation, as well as Vandellós I, Oskarshamn, Chin-Shan and JEN-1 Decommissioning Plans. Currently Westinghouse is working for ENRESA as part of the main engineering for the dismantling of Garoña and Zorita Projects.

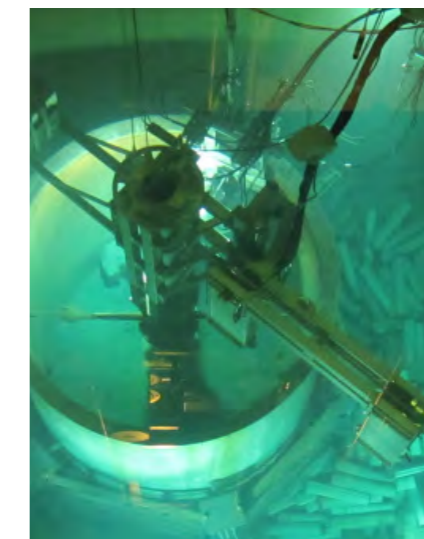

Photo courtesy of ENRESA

NEW PLANTS

Leveraging the accumulated experience gained by Initec in building Spanish plants, Westinghouse's office in Madrid actively supports the detail engineering of the AP1000 reactor in USA.





NUCLEAR POWER PLANTS

—

ANAV, Ascó & Vandellós II Nuclear Power Plants
CNAT, Almaraz I & II and Trillo Nuclear Power Plants
Iberdrola, Cofrentes Nuclear Power Plant
Nuclenor, Santa María de Garoña Nuclear Power Plant

28-39

—

Spanish nuclear power plants operate in a continuous, reliable, safe and clean way, diving growth in their zones of influence.

Headquarters
Apartado de Correos, 48
43890 L'Hospitalet de l'Infant (Tarragona)
Tel.: +34 977 818 800
E-mail: comunicacio@anacnv.com



In 1998, as a result of a merger between the companies that independently managed the Ascó and Vandellós II nuclear power plants, an economic interest group known as Asociación Nuclear Ascó-Vandellós II (ANAV) was born. The rather similar technologies of both plants, and their relatively close locations, led their owner utilities to integrate them into a common management company.

This commitment is embodied both in the Group's investments on the Plants to guarantee their safe and long-term operation, and in direct actions on the

territory, with activities that foster economic, social and cultural development of the towns in the areas of influence of both Plants.

Through its day-to-day business, the staff at Ascó and Vandellós II NPPs have a fundamental role employing a total of 2,075 workers at the end of 2020 between the staff of ANAV and the stable contractor companies, which are one of the fundamental cornerstones for the safe operation of these plants. ANAV in this sense is an economic reference both in the province of Tarragona and in the whole of Catalonia.

One of the strategic communication tools that ANAV has is the Information Center. Since 2011, it has been hosting visits with the aim of giving response and, at the same time, generating new queries among all those who come with the curiosity of knowing what a nuclear power plant is and how it works. This project responds to the multiple objectives of ANAV to contribute to the approach of energy and the operation of the nuclear power plants, to generate an added value that complements the offer of the Ribera d'Ebre to attract visitors to the region and meet the existing demand to the nuclear power plant.

At the end of 2019, the ANAV Information Center incorporated a total of 14 elements from the visitor's center of the Santa María de Garoña nuclear power plant, including modules, information panels and other materials, with the aim of maintaining, and even improving, a fluent speech throughout the entire visit.

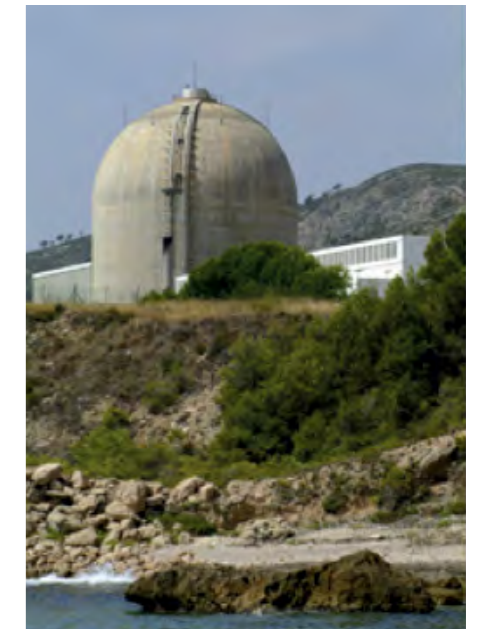

ASCÓ NPP GROSS ELECTRIC POWER PRODUCTION (GWh)

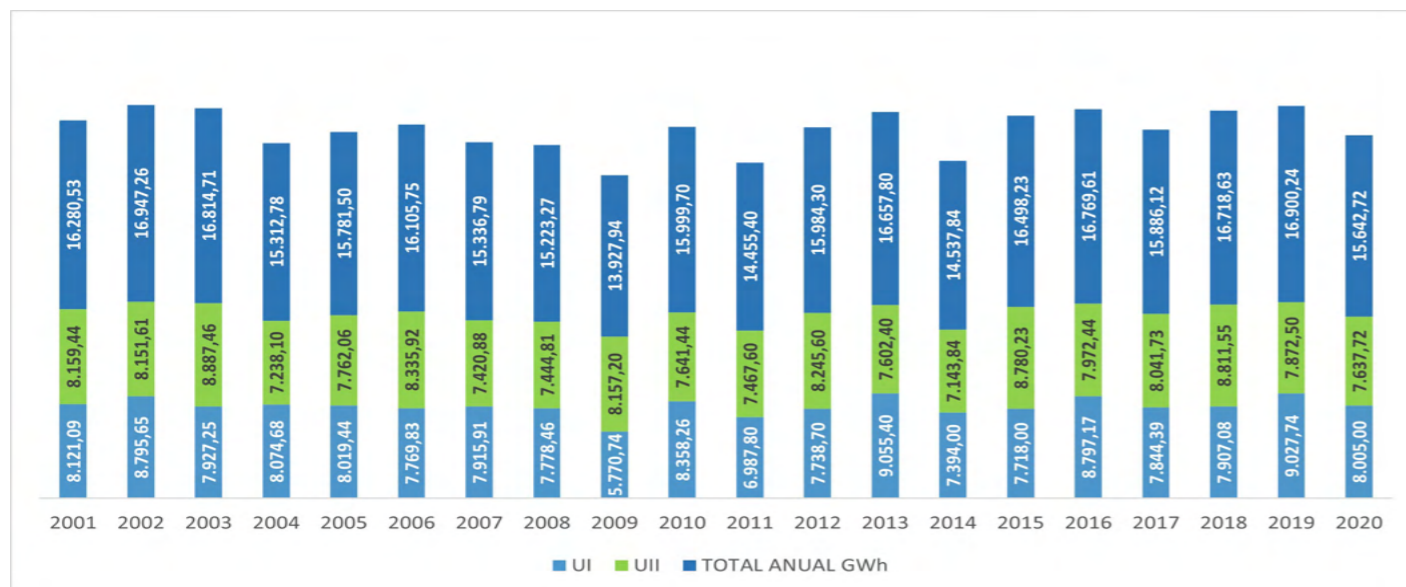

VANDELLÓS II NPP GROSS ELECTRIC POWER PRODUCTION (GWh)

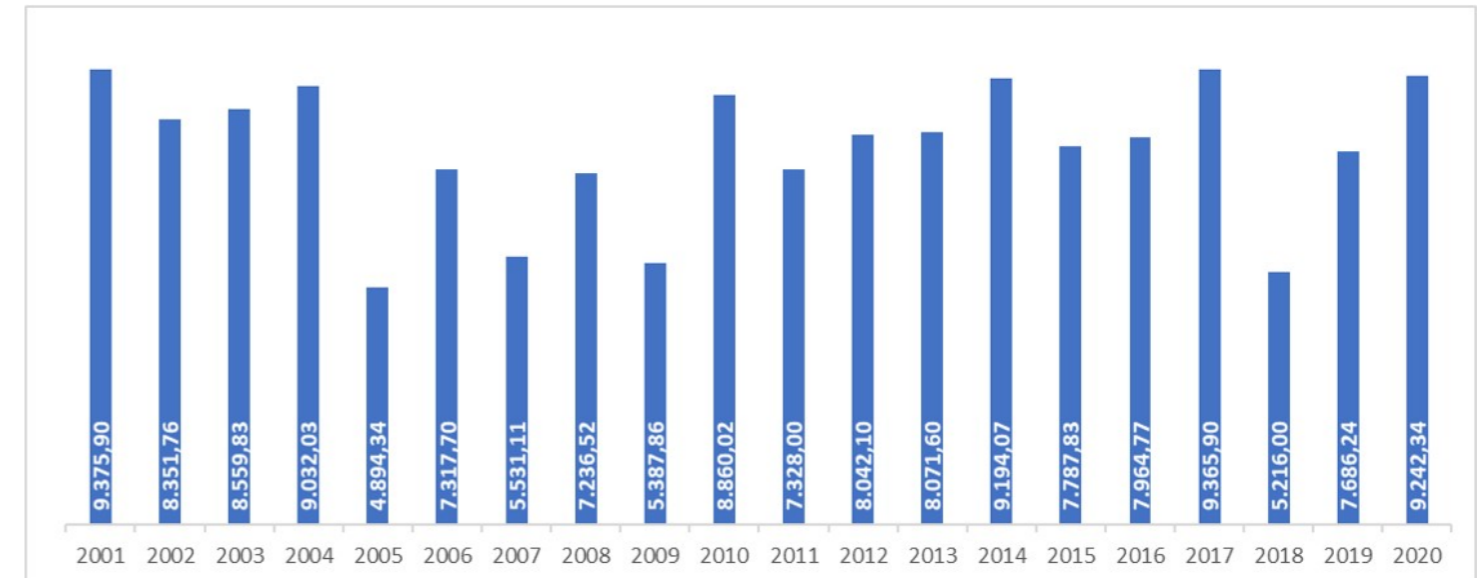

ASCÓ NUCLEAR POWER PLANT

Ascó Nuclear Power Plant
Avda. de la Centrales, s/n
43791 Ascó (Tarragona)
Tel.: +34 977 415 000

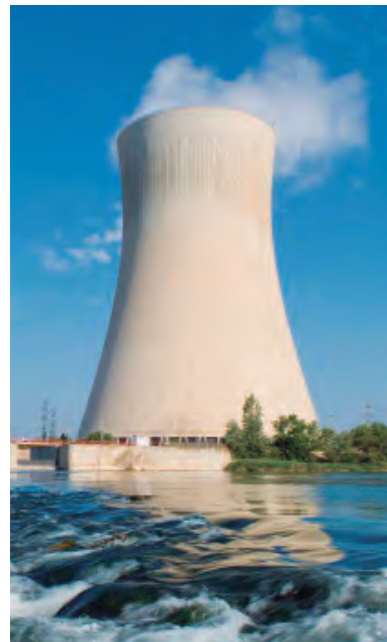

ASCÓ NUCLEAR POWER PLANT

The Ascó Nuclear Power Plant is located on the right bank of the Ebro River in the district of Ribera d'Ebre, in the municipal area of Ascó in the province of Tarragona. Its construction began in 1972 and 81% of the construction and equipment assembly work was carried out by Spanish companies.

The Ascó Nuclear Power Plant has two pressurised water reactors (PWR), the cooling water for the two units is provided by the Ebro River.

Unit I of the Plant, with a thermal power of 2,940.6 MWt and an electric output of 1,032.5 MWe, belongs to ENDESA and it initiated its commercial operation on December 10th, 1984.

Unit II, with a thermal power of 2,940.6 MWt and an electrical output of 1,027.2 MWe, is jointly owned by ENDESA (85%) and IBERDROLA (15%), and it initiated its commercial operation on March 30th, 1986.

The Ascó Nuclear Power Plant employs 476 people, of which approximately half are university graduates. In addition, the Plant has over 611 staff members from stable contractor companies and that during refueling periods there is an addition 900 to 1,200 workers.

ANAV has dedicated 57,340 employee hours to the training of Ascó NPP personnel with a total of 981 courses and 11,599 students.

After 34 years of operation in July 2018, Ascó reached 500,000 GWh of electricity production, a milestone achieved thanks to the professional performance of an outstanding human team.

VANDELLÓS II NUCLEAR POWER PLANT

Vandellós II Nuclear Power Plant
Apartado de correos, 27
43890 L'Hospitalet de l'Infant (Tarragona)
Tel.: +34 977 818 700



VANDELLÓS II NUCLEAR POWER PLANT

The Vandellós II Nuclear Power Plant is located on the Mediterranean coast in the province of Tarragona, in the municipal area of Vandellòs i l'Hospitalet de l'Infant, being the only Spanish Plant that extracts the cooling water necessary for its operation from the sea.

National participation in the construction and supply of equipment for this Plant amounted to more than 89% of the total, the highest percentage achieved in Spain for this type of project.

The Plant has a Pressurized Water Reactor (PWR) with a thermal power of 2,940.6 MWt and an electrical power of 1,087.1 MWe, and is jointly owned by ENDESA (72%) and IBERDROLA (28%). The Plant launched its commercial operation on March 8th, 1988.

The Vandellós II Nuclear Power Plant houses ANAV's corporate headquarters. Between the Plant and the corporate services, the site has a workforce of

988 people, of which 470 are ANAV employees and 518 come from stable contractor companies. During refueling periods there is an addition 900 to 1,200 workers from around 65 local companies.

ANAV has dedicated 64,838 employee hours to the training of Vandellós II NPP personnel with a total of 1,090 courses and 14,292 students.

Currently, the Vandellós II Nuclear Power Plant does not have an information center on site and all visitors are sent to the ANAV Information Center at the Ascó Nuclear Power Plant, except technical or institutional visitors to the Plant.

The re-racking project began in August 2020. The scope of this project consisted in replacing six of the racks that store the spent fuel assemblies in Vandellós II NPP. This allowed the plant to increase its pool storage capacity by 208 positions, which is the equivalent to three operating cycles, about four and a half years.

Ascó Nuclear Power Plant

Reactor type	Pressurised Water Reactor (PWR)
Supplier	Westinghouse
Thermal power	2,940.6 MWt (both units)
Fuel	Enriched Uranium Dioxide (UO ₂)
Nº of fuel elements	157
Gross electrical power	1,032.5 MWe (Unit I) and 1,027.2 MWe (Unit II)
Refrigeration	Open circuit, Ebro River
Start of commercial exploitation	December 1984 (Unit I) and March 1986 (Unit II)
Date of current operating permit	02/10/2011 for a 10-year period
Duration of cycle	18 months (both units)

Vandellós II Nuclear Power Plant

Reactor type	Pressurised Water Reactor (PWR)
Supplier	Westinghouse
Thermal power	2,940.6 MWt
Fuel	Enriched Uranium Dioxide (UO ₂)
Nº of fuel elements	157
Gross electrical power	1,087.1 MWe
Refrigeration	Open circuit Mediterranean Sea
Start of commercial exploitation	March 8th 1988
Date of current operating permit	July 26th 2010
Duration of cycle	18 months

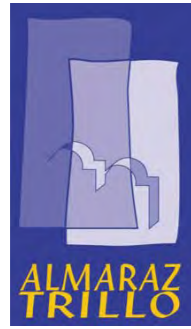

CENTRALES NUCLEARES ALMARAZ-TRILLO, A.I.E.

Headquarters
Avda. de Manoteras, 46-bis
Edificio Delta Norte 3, 5º
28050 Madrid
Tel.: +34 915 559 111



Almaraz Nuclear Power Plant
Apartado de Correos, 74
10300 Navalmoral de la Mata (Cáceres)
Tel.: +34 927 545 090



In November 1999, the owner companies of Almaraz and Trillo nuclear power plants formed an Economic Interest Grouping for the Almaraz-Trillo nuclear Power Plants (CNAT), for the integrated operation, management and administration of both plants.

With this decision, the owner companies (Iberdrola Generación Nuclear, Endesa Generación, Naturgy Generación and Iberenergía) are reinforcing their commitment with the safe and reliable operation of both plants as well as to their trust in nuclear power, an environment-friendly and diversified sector.

The Grouping has a staff of 815 employees, distributed between the central headquarters in Madrid with 95 employees, 391 in the Almaraz Power Nuclear Plant and 329 in the Trillo Nuclear Plant.



ALMARAZ NUCLEAR POWER PLANT

The Almaraz Nuclear Power Plant is located in the village of Almaraz (province of Cáceres). The land on which the plant stands occupies a surface of 1,683 hectares. It belongs to Iberdrola Generación Nuclear, S.A.U. (52.687%); Endesa Generación, S.A.U. (36.021%); and Naturgy Generación, S.L.U. (11.292%). Construction started in 1972 and 81% of all the construction and assembly work was carried out by Spanish companies.

The Almaraz nuclear power plant has two pressurised light water reactors (PWR) with a thermal power of 2,947 MWt each, and an electrical power of 1,049.43 MWe in Unit I and 1,044.45 MWe in Unit II.

Each reactor has a cooling circuit comprising three loops. Each loop in turn has a cooling pump and a steam generator. Both cooling circuits are contained in their respective containment areas in each reactor building.

Type of reactor	Pressurised Water Reactor (PWR)
Supplier	Westinghouse
Thermal power	2,947 MWt (U-I) - 2,947 MWt (U-II)
Fuel	Enriched Uranium Dioxide (UO ₂)
Nº of Fuel elements	157
Gross electrical power	1,049.43 MWe (U-I)-1,044.45 MWe (U-II)
Net electrical power	1,011.30 MWe (U-I)-1,005.83 MWe (U-II)
Cooling	Arrocampo dam open circuit
Start of commercial operation	September 1, 1983 (U-I). July 1, 1984 (U-II)
Date of current operating license	UI - 24/07/2020 for a 7-year period UII - 24/07/2020 for an 8-year period
Duration of cycle	18 months (both units)



The steam from the generators is taken to the turbine buildings which houses the two turbogroups, in the same room, but separated. The cooling system (common for the two sites) is an open circuit from the cold spot which is the Arrocampo dam, constructed for this purpose.

Unit I started its commercial service on 1st September 1983 and Unit II did so on 1st July 1984. It is conceived to operate as a base plant, that is, with uninterrupted operation, and it is capable of guaranteeing an average annual supply of 16,000 million kWh.

The Almaraz Nuclear Power Plant provides around 7% of the national production of electrical energy. During its years of operation, the two plant units have obtained excellent results in their performance with load factor, operation and availability of more than 90% and have accumulated until december 2020 a production of 561,527.308 GWh. These results put the Almaraz Nuclear Power Plant among the best in the world park of nuclear power plants.

The Almaraz Nuclear Power Plant has a staff of 391 people, of which 48% have a university degree, plus the collaboration of highly qualified personnel from contracting companies. Training is a key factor for the constant improvement of safety, quality, efficiency and competitiveness.

In order to let the public know about the reality of its activity, it has an Information Centre which started to receive visits in

February 1977, years before the plant started its operation, allowing visitors to have a more direct knowledge of what a nuclear power plant is and how it works

Since its opening the Information Centre has received 670,519 visitors. Most of them are students from institutes, schools and universities and mainly from the community of Extremadura.

GROSS ELECTRIC ENERGY PRODUCTION UI+UII (GWh)

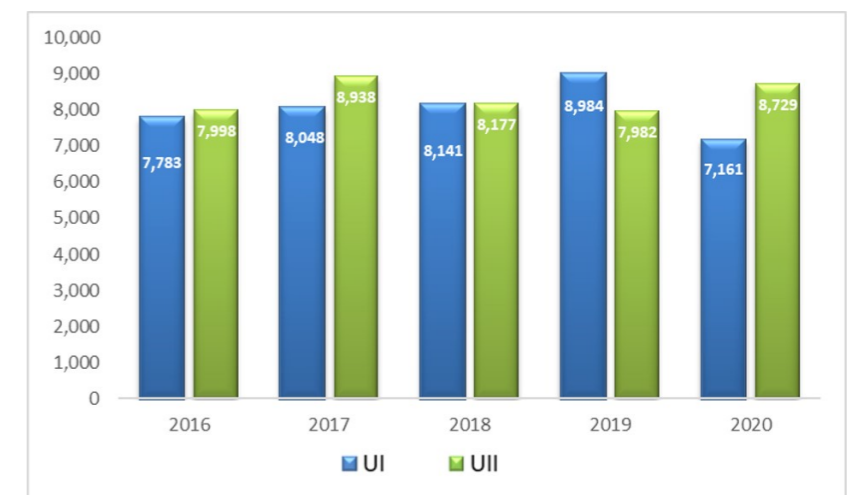

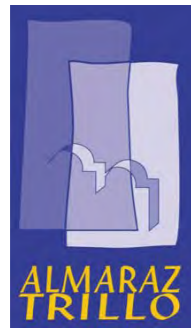

CENTRALES NUCLEARES ALMARAZ-TRILLO, A.I.E.

Headquarters
Avda. de Manoteras, 46-bis
Edificio Delta Norte 3, 5º
28050 Madrid
Tel.: +34 915 559 111



Trillo Nuclear Power Plant
Apartado de Correos, 2
19450 Trillo (Guadalajara)
Tel.: +34 949 817 900



TRILLO NUCLEAR POWER PLANT

The Trillo Nuclear Power Plant is located in the village of Trillo (province of Guadalajara). The land on which the plant is built occupies a surface of 545 hectares. It is the property of the following Spanish electrical companies: Iberdrola Generación Nuclear, S.A.U. (49%); Naturgy Generación, S.L.U. (34.5%); Iberenergía, S.A.U. (15.5%) and Endesa Generación, S.A.U. (1%) *

*Endesa has directly become a shareholder of Trillo NPP. The complete divestment and exit operation of Nuclenor from the ownership of TRILLO I and CNAT AIE has resulted in ENDESA GENERACIÓN acquiring its share of ownership of TRILLO I NPP (1%) and its participation (0.34%) in CNAT AIE in proportion to their respective status as 50% shareholder of NUCLENOR. The other shareholder, IBERDROLA GENERACIÓN NUCLEAR, S.A.U. with 50% of NUCLENOR, also acquires the same ownership stake in TRILLO NPP (1%) and participation (0.34%) in CNAT AIE. The operation was formalized in the second semester of 2020.

Construction started in 1979 and 85% of the investment made is from Spanish origin. National engineering and equipment exceeded 80% and such important areas as civil engineering and assembly were all national.

The Trillo Nuclear Power Plant has a pressurised light water reactor (PWR) with a thermal power of 3,010 MWt and an electrical power of 1,066 MWe with a cooling circuit with three loops. Each loop in turn houses a cooling pump and a steam generator. This circuit is contained in the containment area of the reactor building. The steam from the generators is taken to the turbine building. The cooling system is a closed circuit with two natural draught towers.

It started its commercial operation on 6th August 1988. It is conceived to operate as a base plant, with uninterrupted operation and guarantees an average annual supply of 8,000 million kWh and is the most modern plant in the Spanish nuclear park.

The Trillo Nuclear Power Plant has a temporary dry warehouse which stores part of the spent fuel inside metal containers which are totally hermetic and shielded. With a surface of 2,280 square meters, this warehouse is designed to house 80 containers.



Type of reactor	Pressurised Water Reactor (PWR)
Supplier	KWU
Thermal power	3,010 MWt
Fuel	Enriched Uranium Dioxide (UO ₂)
Nº of fuel elements	177
Gross electrical power	1,066 MWe
Net electrical power	1,003 MWe
Cooling	Natural Draught Towers (River Tagus)
Start of commercial operation	August 1988
Date of current operating license	17/11/2004 for a period of 10 years
Duration of cycle	12 months



During its years of operation, the plant has obtained excellent results in its operation, with load factors, operation and availability of more than 90% and have accumulated until december 2020 a production of 264,024.77 GWh. It is worth mentioning that in 2003 the plant reached 9,304,908 MWh (maximum production in a cycle).

The Trillo Nuclear Power Plant has a staff of 329 people, of which more than 48% have a university degree, plus the collaboration of highly qualified personnel from contracting companies.

Training is a key factor for the constant improvement of the levels of safety, quality, efficiency and competitiveness.

The Trillo Nuclear Power Plant has an Information Centre which started to receive visits in November 1981, years before the plant started to operate, allowing the visitors to have a more direct knowledge of what a nuclear power plant is and how it works

Since it was opened the Information Centre has received 367,775 people. Most of them are students from institutes, colleges and universities, mainly from the Autonomous Communities of Madrid and Castilla La Mancha.

GROSS ELECTRIC ENERGY PRODUCTION (GWh)

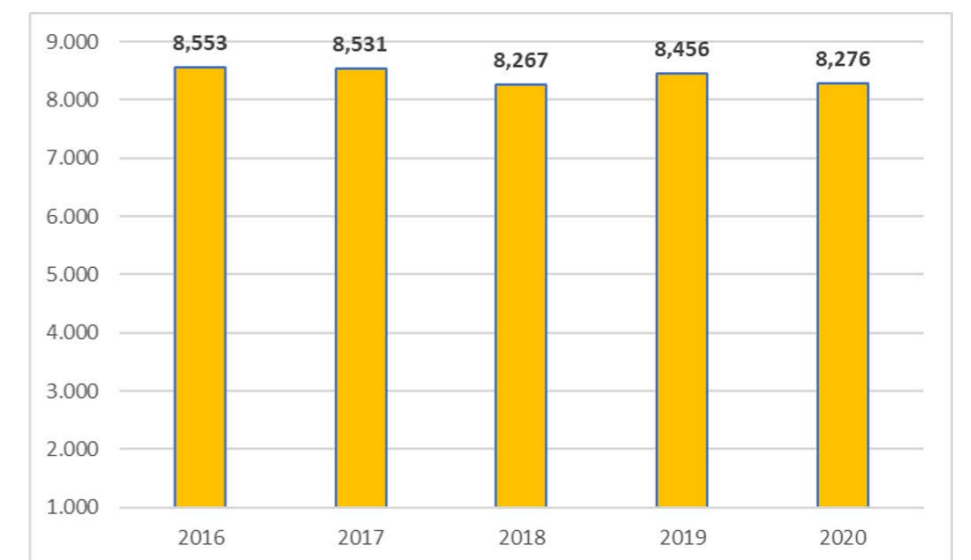



COFRENTES NUCLEAR POWER PLANT

Iberdrola Nuclear Generation
C/ Tomás Redondo, 1
28033 Madrid
Tel.: +34 915 776 500



Nuclear Power Plant
46625 Cofrentes (Valencia)
Tel.: +34 961 894 300
E-mail: cncofrentes@iberdrola.es



Cofrentes nuclear power plant is owned by the utility Iberdrola Generación Nuclear, S.A.U.

Cofrentes NPP is located in the municipality of Cofrentes (province of Valencia), on the right bank of the Júcar River.

The plant has a nuclear system for steam generation comprised of a light-water boiling water reactor (type BWR/6) supplied by the USA corporation General Electric Company,

with a thermal power of 3,237 MWt and an electric power of 1,092 MWe. Plant cooling is ensured by a closed-loop circuit, including two natural-draught cooling towers.

The construction permit was granted in 1975, being connected for the first time to the grid in October 1984. In 2020, the station had operated for 36 years, with an

accumulated generation since commissioning until December 31, 2020 of 289,296 million kWh.

Cofrentes nuclear power plant is currently one of the main power generation facilities in Spain, contributing in 2020 some 3.7% of power within the regular energy production framework. In the Valencia Region, where the station is located, annually produces about 46% of total electricity

Ever since it began commercial operation in 1984, Cofrentes NPP has operated under high safety and reliability standards, making a significant contribution to Spain's electrical grid supply stability and guarantee. Site results over the last decade confirm a trajectory of continuous improvement, which is the result of upgrade and investment projects and efforts by our team of professionals.

According to data published by the Spanish Regulator (CSN), the station has been since 2011 in the "Licensee Response" column, best safety position within the Spanish equivalent of the Reactor Oversight Process (SISC) of CSN.

Cofrentes NPP its one of the most reliable stations in the international arena: The specialized publication Nuclear Engineering International, June 2020 issue, published a ranked list of all nuclear power plants worldwide according to the historical load factor. In that list, Cofrentes NPP ranks 31 out of 440 reactors, meaning the station is one of the best in the world in terms of performance, safety and reliability.

It has operated over 11 years without a scram, a milestone achieved only by 40 reactors of the 440 currently in operation, according to WANO (World Association of Nuclear Operators) indicators.

The operating cycle is as follows:

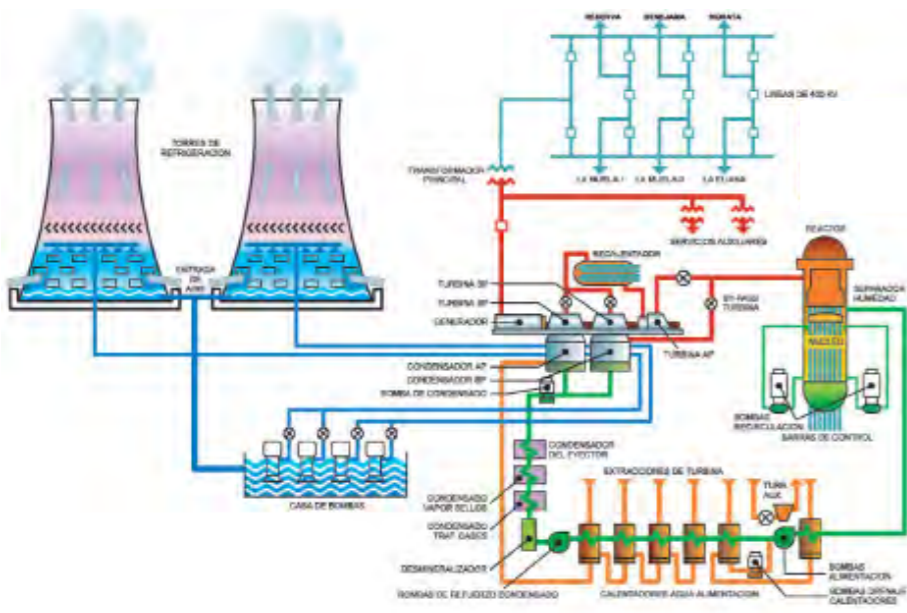

Reactor type	Boiling Water Reactor (BWR)
Vendor	General Electric
Thermal power	3,237 MWt
Fuel	Enriched Uranium Dioxide (UO ₂)
Number of fuel assemblies	624
Electric power	1,092 MWe
Cooling	Closed-loop circuit with natural-draught cooling towers
First electrical network connection	October 1984
Start of commercial operation	March 1985
Date of last Operating Permit	Since 18th March, 2021 to 30th November, 2030

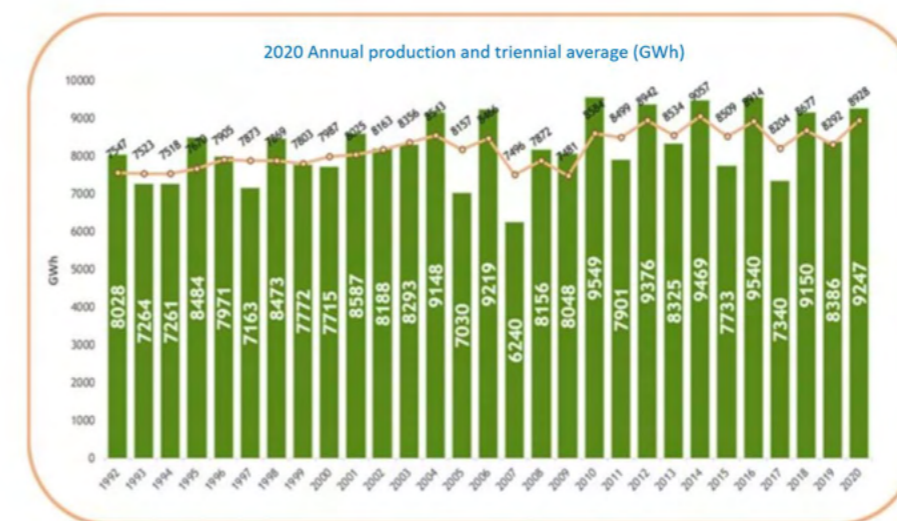

Electricity generated by Cofrentes NPP is carbon-free, meaning the station prevents the release of five tons of CO₂ into the atmosphere yearly, being a key contributor to the fight against climate change.

Throughout its history, Cofrentes NPP has allocated significant sums of money to continuously upgrade the site and technologically optimize equipment, all with the aim to ensure safe, reliable and sustained performance. Over the last decade, more than €450 million were invested to this end, favoring station readiness to ensure safe operation over the next few years. These investment programs are an important economic and social driver for the Valencia Region, especially for development of inland areas within Valencia, in the area between Requena and Almansa, where Ayora-Cofrentes valley is included

The site has undertaken a large upgrade and digitalization initiative to optimize multiple processes, equipment and components through technological

On March 18, 2021, the Department of Energy Transition and Demographic Challenge granted Cofrentes nuclear power plant the renewal of its operating permit until November 2030. This decision was made after favorable assessment of the Spanish Regulator (CSN), which performed

The station currently has an Alternative Emergency Management Center (Spanish acronym: CAGE); a Safe Seismic Storage Area for portable equipment; Passive Autocatalytic Recombiners (PAR) in the Containment and Drywell; a new seismic fire protection system and the filter containment ventilation system.

an ongoing monitoring and supervision of plant operating conditions and compliance with applicable regulations in the areas of nuclear safety and radiation protection. This renewal complies with the provisions of the National Integrated Plan for Energy and Climate (PNIEC).



SANTA MARÍA DE GAROÑA NUCLEAR POWER PLANT

Nuclear Power Plant
09212 Santa María de Garoña (Burgos)
Tel.: +34 947 349 400
E-mail: secre.cnsg@nucenor.es



The **Santa María de Garoña Nuclear Power Plant** is located in the province of Burgos, on the right-hand bank of a curve in the river Ebro near the village of the same name in the Tobalina Valley at the upstream end of the Sobrón reservoir. It is owned and run by NUCLENOR, S.A. (50% Iberdrola and 50% Endesa). Founded in 1957, it was pioneer in Spain in the use of nuclear energy for the generation of electricity. The plant has not produced electricity since the December 16, 2012.

As a result of the decisions reached by Ministry for Industry, Energy and Tourism (IET) Order/1302/2013, of July 5, which stipulates the definitive cessation of operation of the Santa María de Garoña

Nuclear Power Plant, and Ministry for Energy, Tourism and Digital Agenda (ETU) Order/754/2017, of August 1, which rejects the Operating Licence Renewal Request (SRAE), on August 3, 2017, and under the management of Spain's National Radioactive Waste Management Company (ENRESA), the Santa María de Garoña Nuclear Power Plant began its phase of transition or pre-dismantling period, which saw it implement activities in preparation for its eventual decommissioning.

The characteristic activities of this phase involve the processing of the operational radioactive waste, preparing for dismantling and managing the spent fuel.

ELECTRIC PRODUCTION 2002-2013 (MILLION OF KWH)

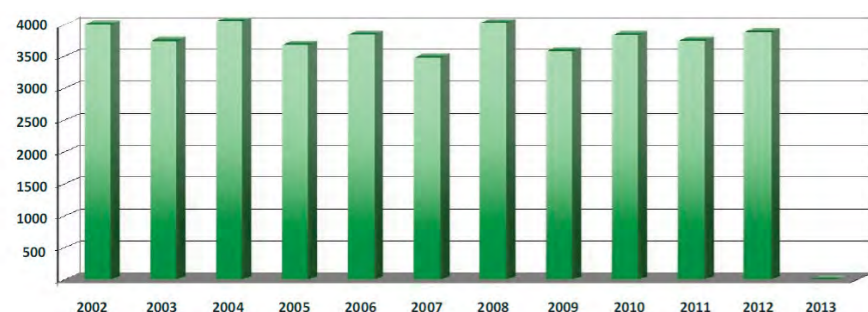

In the case of Garoña, instead of the plant managing the spent fuel, the idea is to develop a spent fuel management plan approved by the Spanish Regulator (CSN) in order to be able to undertake the transfer of registered ownership prior to the commencement of dismantling, thus enabling a reduction of the terms for completion while retaining the existing knowledge of the facility.

In June 2020 ENRESA contracted the supply of the containers required for the total removal of the fuel rods stored in the spent fuel pool.

Based on the foregoing, ENRESA has proposed a two-phase dismantling process for Garoña aimed at separating the onset of dismantling from the management of the spent fuel, thus enabling the commencement of certain dismantling works:

- Phase 1, which will consist of the disassembly of the turbine building equipment at the same time as the removal of the fuel rods stored in the spent fuel pool and their subsequent transfer to the Temporary Individualised Store (ATI), and
- Phase 2, which will consist of the dismantling of the entire plant.



On May 21, 2020, ENRESA presented the Ministry for the Ecological Transition and the Demographic Challenge (MITERD) with the authorisation request for Phase 1 of the dismantling of the Santa María de Garoña Nuclear Power Plant and for the

Reactor type	Boiling Water Reactor (BWR)
Supplier	General Electric
Thermal power	1,381 MWt
Fuel	Enriched Uranium Dioxide (UO ₂)
Nº of fuel elements	400
Electrical power	466 MWe
Cooling	Open circuit, Ebro river
Start of comercial operation	March 1971
Duration of cycle	24 months

transfer of registered ownership, in which the information regarding the ATI is included.

On the same day, ENRESA also submitted the Santa María de Garoña Nuclear Power Plant Spent Fuel Management Plan to the MITERD in compliance with that set forth in article 28.2.a) of the Regulations Governing Nuclear and Radioactive Installations (RINR).



During 2020, the plant kept all the fuel stored in the reactor building pool, where it will be maintained in safe conditions until it is transferred to the ATI.

Nucenor's main priority in this phase of transition to decommissioning has continued to be the safe operation and maintenance of the spent fuel and radwaste without operating incidents or industrial accidents and rigorous compliance with the standards and requisites established by the CSN.

2020 saw significant changes in the organisation of the works in question due to the implementation of COVID-19 prevention measures.

This period saw the plant's workforce involved in the following projects implemented in accordance with the transition phase, always in close collaboration with ENRESA:

- The drafting of the Spent Fuel Management Plan (PGCG), which will define the main aspects of how the

plant's fuel is managed, and the development of the agreements required for the transfer of registered ownership.

- The final configuration and modifications of the spent fuel pool cooling systems the objective of which is the global optimisation of the plant's systems after more than six years cooling the irradiated fuel by maintaining the required safety functions with the following objectives: focusing monitoring on the important safety systems, reducing risks, facilitating the pre-decommissioning activities and adapting the plant to international standards.

- The systems reconfiguration project has involved a large number of discharges and associated design modifications, such as the installation of a new diesel generator to supply power to two motor control centres, modifications in the 125 VC distribution system, or changes in the power supply to the distribution panels of the essential busbars, to mention just a few of the twenty or so modifications made.

- In August 2020, the CSN approved the design modifications of the official shutdown documents (DOPs) associated with the systems reconfiguration. This enabled the implementation of the new Operational Specifications, Health and Safety Study and Operation in Shutdown Regulations, with the organisational changes they imply.

- The plant and ENRESA are also collaborating on the management of the irradiated fuel, which is centred on preparing the Temporary Individualised Store (ATI) designed to house the first five containers manufactured by ENSA together with the rest of the containers to be supplied to enable the eventual removal of all of the fuel rods stored in the

spent fuel pool. The reactor building crane was also tested under load last year in order to ensure problem-free handling of the spent fuel containers when required.

- ENRESA and the plant worked together on the tendering and award of the remaining containers required for the removal of all the fuel rods stored in the spent fuel pool and their subsequent move to the ATI.

- The collaboration with ENRESA also involved the planning and implementation of preparatory dismantling activities, including:

- Risk mitigation, system decontamination, appraisal and characterisation of the site pending, conventional disassemblies, modification of auxiliary installations and modification of systems.
- Planning and preparation for the removal of the heat insulation from the turbine building
- Adaptation of the existing warehouses for the storage of very low-level wastes
- Planning the works for a future base for the ENRESA organisation at Santa María de Garoña.

In August 2020, the Constitutional Court of Spain declared the tax levied by the Autonomous Regional Government of Castilla y León on the temporary storage of nuclear waste at the plant to be unconstitutional, thereby resulting in its cancellation.





FUEL



ENUSA Industrias Avanzadas, S.A., S.M.E.

42-43



A Spanish company is responsible for all stages of the nuclear fuel production process, from the delivery of raw materials, through to their processing and manufacturing.



ENUSA INDUSTRIAS AVANZADAS S.A., S.M.E.

Headquarters
C/ Santiago Rusiñol, 12
28040 Madrid
Tel.: +34 913 474 200
E-mail: comunicacion@enusa.es



Juzbado Fuel Assembly Factory
Road Salamanca-Ledesma, km 26
37115 Juzbado (Salamanca)

Saelices el Chico Center
Crta. Ciudad Rodrigo a Lumbrales, km 7
37592 Saelices el Chico (Salamanca)



ENUSA Industrias Avanzadas, S.A., S.M.E. (ENUSA) was founded in 1972 as the National Uranium Company. It was part of an initiative that intended to strengthen the importance of the nuclear component in Spain's energy development. Today ENUSA is a public Enterprise 60% owned by the Sociedad Estatal de Participaciones Industriales (SEPI), and the remaining 40% by the Centro de Investigaciones Energéticas, Medioambientales y Tecnológicas (CIEMAT). **ENUSA is the parent company of the ENUSA Group, jointly with ETSA Global Logistics S.A.U., S.M.E. (ETSA) and Empresa para la Gestión de Residuos Industriales S.A., S.M.E., M.P. Emgisa,** focuses its activities in the nuclear fuel cycle and develops environmental services.

PURPOSE

ENUSA's purpose is to develop innovative nuclear and environmental solutions at a global level, contributing to the sustainable progress of society through the values of Safety, Flexibility, Innovation, Commitment and Collaboration.

ACTIVITIES AND REFERENCES

The **nuclear business** focuses on activities of the nuclear fuel cycle that are marketed both nationally and internationally and which services consists of:

- Management of the enriched uranium supply to the Spanish nuclear power plants under the criteria of security and flexibility.
- Engineering in all technical aspects of the lifetime of the nuclear fuel, from design and operation in the nuclear power plant up to his tenure as irradiated fuel for transport and dry storage.
- Manufacturing and fuel assemblies to national and foreign nuclear power plants for:
 - Pressurized water reactors (PWR), under Westinghouse license.
 - Boiling water reactors (BWR) under General Electric license.
 - Pressurized water reactors (VVER), in collaboration with Westinghouse.
- Coordination the handling, inspection and repair campaigns that take place during the refueling programs, providing fresh fuel reception and irradiated fuel handling services and supervising the process during the reload (inspection, repair, characterization and cleaning)

- Transport of nuclear and radioactive materials through the subsidiary ETSA.

As part of the nuclear activities, we also develop technological capabilities for the second stage of the fuel cycle and the sale of fresh and irradiated fuel manufacturing and inspection equipment. The subsidiary Emgrisa is **environmental brand** of the ENUSA Group and offers a wide range of services aimed at preserving the environment and ensuring an efficient use of energy.

- Waste treat and management all kinds of (waste):

- Hazardous and non-hazardous industrial waste. Collection, transport and management of hazardous and non-hazardous industrial waste, prioritizing waste reuse and recovery.
- Municipal Solid Waste. Design, construction and operation of MSW recovery facilities with biodrying and accelerated oxidation technology using airflow. Odour free system and no contact with the waste.

- Agricultural, Livestock and Agro-industrial Waste. Plants design for agronomic valorization of digestate and energy (biogas).

- Characterization and treatment of contaminated soils and groundwater. Performance of all kinds of environmental site assessment on soil and groundwater contamination.

- Radiological studies
- Engineering and environmental consultancy.

As a complement to these activities, the environmental area supervises the reclamation of former uranium mining facilities in Saelices el Chico and La Haba, the purpose of which is to try to restore the affected natural space to its original state with environmental and radiological

Turnover	227 million €
% from fuel sales that go to R&D projects	More than 3%
Staff number average	664 employees

Manufacturing cumulative form 1985 to 2020	PWR	BWR	TOTAL		
	Total	Total	National	Exportation	Total
tU	6,446	2,030	4,352	4,124	8,476
EECC (units)	14,047	11,301	12,118	13,230	25,248

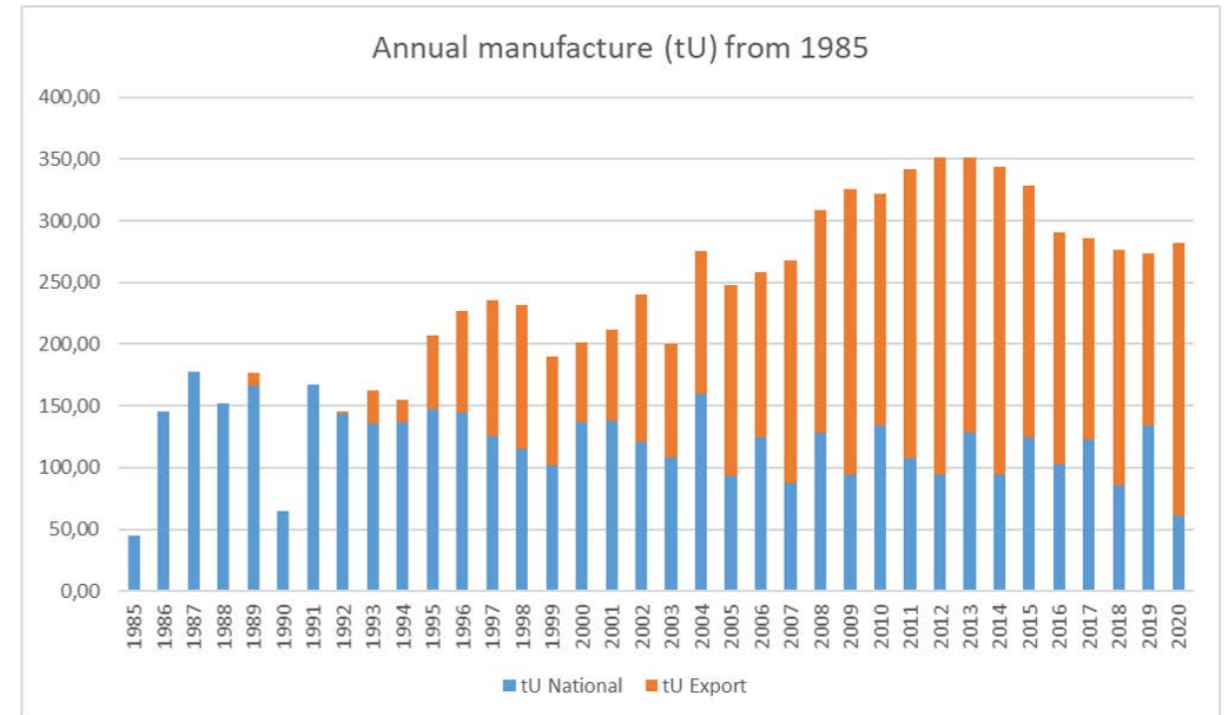

conditions as similar as possible to those existing before the mining operations.

Currently ENUSA has three work centers. Two of them are industrial sites: a fuel assembly factory in Juzbado and a center in Saelices el Chico (Ciudad Rodrigo). Both of these are in the province of Salamanca. The corporate headquarters are in Madrid. ENUSA also manages a solid urban waste plant in Cervera del Maestre (Castellon).

Since 1985, the Juzbado factory manufactures uranium pellets, assembles fuel elements and develops equipment for the manufacture and inspection of elements for PWR and BWR.

In 2020, ENUSA Industrias Avanzadas, S.A. S.M.E. has manufactured 289 tU enriched, of which 204 have been for pressurized water reactors (PWR) in Spain, France and Belgium. In Spain, the supply of fuel has continued on a regular basis to the Spanish PWR nuclear power plants of Westinghouse design. In this

year 2020, 68 enriched tUs have been manufactured and 192 fuel elements have been delivered to the Almaraz 1, Ascó I and Ascó II Power Plants.

For the commercialization of boiling water reactors (BWR) fuel in the market, ENUSA has participated since 1996 in the GENUSA company with General Electric, which in Spain is destined for the Cofrentes nuclear power plant. In 2020, 85 tU enriched were

manufactured for this type of reactors, representing almost 30% of the total production.

The Juzbado fuel elements plant manufactured 289 tU, 6% more than in 2019 despite the difficulties, of which 76.5% were exported.

Of the 907 assembled fuel elements, 417 were pressurized water (PWR) and 490 were boiling water (BWR).





EQUIPMENT GOODS

CEN Solutions
Coapsa Control, S.L.
Equipos Nucleares, S.A. S.M.E.
Konecranes
Newtesol, S.L.
Nusim, S.A.
Ringo Válvulas, S.L.
Taim Weser, S.A.

46-61

Equipment goods manufacturing companies export more than 80% of their output.



BUSINESS OBJECTIVE

CEN Solutions performs its activities in the energy, Oil&Gas, industry and water sectors, through two main business lines which are the manufacturing of electrical equipment and provision of services, including preventive and corrective maintenance activities.

The manufacture of safety equipment is a key activity within the strategic development of the company, with capacity for the supply of control panels and consoles, auxiliary panels for reactor protection systems, sampling equipment, power centers and distribution switchboards, motor control centers, medium voltage switchgears, isolated phase bus ducts, dry transformers, and power electronics.

The design and manufacture of the equipment is carried out at the company's premises in the free zone of Seville, with a total area of 60,000 m².



SERVICES, PRODUCTS AND TECHNOLOGY AVAILABLE

To ensure good performance in terms of quality, environment and safety, CEN Solutions has management systems in accordance with the requirements of ISO 9001, ISO 14001, PECAL 2120, NQA-1: 1994, 10CRF50 Appendix B, UNE 73401: 1995, ANSI Standards and ASME Codes, which are periodically audited allowing the homologation and accreditation as a supplier of Nuclear Safety equipment (Class 1E) at national and international level.

The use of the most advanced manufacturing processes and technology, including qualification tests in accordance with the applicable regulations in each case (IEC, IEEE) and compliance with the strictest requirements of control and quality assurance, allow us to offer the most appropriate equipment and assemblies that, in compliance with current standards and satisfaction of the customer needs.

We also have our own capacities for commercial dedication of electrical components, performed for the components of the products we manufacture or spare parts required by the different Nuclear Power Plants.

CEN Solutions maintains a highly specialized technical team and the qualifications required for the nuclear sector, which have allowed it to continue offering uninterrupted global solutions for the supply of safety and commercial equipment from the beginning of the industry.

The permanent contact with the most specialized companies in the nuclear field, makes CEN Solutions aware of the new technological advances and can be present in the nuclear power plants in Spain and abroad.

NATIONAL AND INTERNATIONAL OUTSTANDING ACTIVITIES

Among the most recent references for the nuclear sector are the following work and supplies:

NATIONAL NUCLEAR POWER PLANTS

- Supply of spare parts (Motor Control Center drawers, auxiliary material) (Almaraz NPP, Trillo NPP, Ascó NPP and Vandellós II NPP).
- Supply of 6.3 kV switchgears, transformation centers and MCC, train A, B and N for EJ project (Vandellós II NPP).
- Provision of labor for main site and control room works (Almaraz NPP).
- Supply of power centers and CCM for power increase (Almaraz NPP).
- Supply additional column CF 2B1A (Almaraz NPP).
- Design, manufacture and assembly of modular electric room for TC cooling towers system (Almaraz NPP).
- Design, manufacture and assembly of modular electric room for water treatment (Almaraz NPP).
- Supply of 20kV and 6.3kV switchgears, Teva project transformation center (Almaraz NPP).

Turnover (2020)	15,064,595 €
Export figure	85%
Staff	144 employees



- Recharge 10kV low voltage busbar review service (R432). CN Trillo.
 - Replacement of Metron Recharge (R432) .CN Trillo switches.
 - GZ40J001 control panel. CN Trillo.
 - Supply of spare material for CC.NN. in Spain.
 - Execution of design modifications for both electricity and instrumentation and control for the plant improvements, among which it is worth highlighting recently those related to the increase in power, TEVA refrigeration project, Change of the public address system and cooling towers (CN Almaraz I and II).
- Execution of Alternative Shutdown Panels and Centralization Switchboards (Almaraz NPP).
- Execution of electrical design modifications of various systems (Trillo NPP).



INTERNATIONAL NUCLEAR POWER PLANTS

ABWR by GE Hitachi

- Main Control Room Panels and Remote Shutdown Panels (Simulator, Units 1 and 2).
- FMCRD relay logic panels and self-firing solenoid fuse panels (units 1 and 2).
- HCU self-test panels (units 1 and 2).
- Systems of sampling and analysis of liquids of secondary systems.
- Meteorological control panels.
- NUMAC panels: NMS panels, optical fiber panels, ATIP & MRBM panels, PRM panels, RTIF panels (units 1 and 2).
- Provision of labor for review in plant and control room.

China Nuclear Power Engineering & China Techenergy Co. LTD.

- Main Control Room Panels and Remote Shutdown Panels for Fuqing NPP (Simulator, units 1 and 2).
- Main Control Room Panels and Remote Shutdown Panels for Fangjianshan NPP (Simulator, 1 and 2).
- Main Control Room Panels and Remote Shutdown Panels for Hainan NPP (Simulator, units 1 and 2).
- Provision of labor for supervision and modifications in the Fuqing and Fangjianshan NPPs.
- Instrumentation for the main control rooms for Hongyanhe NPP 5 & 6.

Nuclear Fusion Technology

Long-term projects in which the company participates

- Review of bars of 10 kV and low voltage and Metron switch replacement during recharges (2018-2022) for CN Trillo.
- Design and supply of the Safety Control System - Nuclear (SCS-N) for Iter.
- Recalification of NC motor control center drawers. Ascó NPP.
- Retrofit of low voltage breakers in 1E and NC DC busbars. Cofrentes NPP.

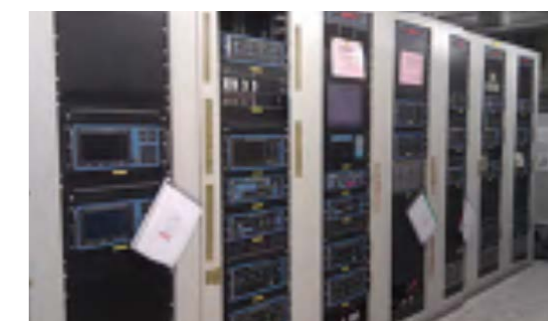

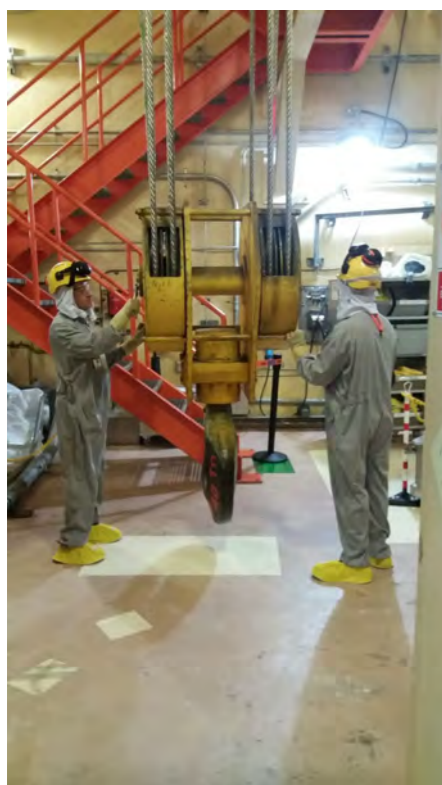

Coapsa is consolidated as a company of reference handling of heavy loads in the nuclear market.

The objective of Coapsa, which was set up in 1997, is to offer our clients the most complete service, addressing problems globally from design to turnkey delivery and even anticipating us to them.

Thanks to our team, the company has achieved continuous growth in the sectors in which we carry out our activity, among others in the fields of industrial automation, equipment goods and in the nuclear industry.

To achieve the growth that they have reached, they have based their work on three key principles:

- Offering quality and good service in every work we do.
- Counting on a professional and highly trained human team capable of offering quick solutions to any possible problems that may appear on the development of each project.
- Adapting to the new technologies that appear on the market, integrating them on the equipments supplied to our customers.

BUSINESS OBJECTIVE

Since our very beginning Coapsa has had the ability to carry out the design, assembly, installation and start-up, in addition to the compliance with all the applicable quality assurance requirements as regards the control and automation of industrial processes and systems.

From the very beginning, the orientation within the sector has traditionally been towards control systems for lifting and handling equipment of heavy and special loads, among others, high precision heavy duty gantry cranes: polar and turbine cranes... and for nuclear fuel handling systems: refueling machines, manipulators, gantry cranes for the handling of spent fuel casks, etc.

At present we have experience in the qualification of the Single Fault Criterion applied to gantry cranes (Nureg-0554 and Nureg-0612) and in the design, manufacturing and assembly of equipment with environmental seismic qualification 1E.

In addition, we have consolidated experience on the port and harbor machinery markets, for the handling of containers and merchandise, as well as

on the equipment for other industrial processes in general: MDD's Low Voltage Distribution Centers, control systems and monitoring of industrial processes, remote control systems for the handling of devices on underground rail networks, etc.

Coapsa's objective is to extend and improve the services we offer on our consolidated market, for which we are improving and extending all our human and material resources in order to bring them into line at all times with the quality and service required by the type of work we perform.

SERVICES, PRODUCTS AND TECHNOLOGY AVAILABLE

ENGINEERING

We offer a complete integrated service adjusted to the client needs, supported by our qualified personnel and our experience.

- Wide experience in the design of conceptual, basic and in detail engineering.
- The use of the principal technologies makes us to be able to give the best solution and assure the total integration of our client's facilities.
- Economical and technical viability studies.
- Planning and monitoring.
- Comprehensive automation projects of industrial processes.
- Automation and improvement of existing processes.
- Migration of control systems, PLC's and industrial communication from the main manufacturers.
- SCADA systems programming including prescriptions, reports, control charts, etc.
- Electronic design using the most avant-grade tools from the market (E-plan, Autocad, etc.).

Estimated turnover at the end of 2019	2,5 million €
% volume of sales that comes from the nuclear sector	65%
Staff	30 employees
Bachelor's degree	12
Specialised operators	16
Other personnel	2

MANUFACTURING

We are manufacturers of electrical equipment, low voltage distribution equipment, regulation equipment, Motor Control Centers, etc. applying the latest technologies existing on the market.

- Distribution and Power equipment.
- Automation and Control equipment.
- Motor Control Center with fixed and removable execution.
- Intelligent Motor Control Center. We offer solutions to any kind of industrial installation, adapting to any requirement of the sector and client.
- Supervision and Control Systems (SCADA) and Distributed Control Systems (DCS).
- Desks, consoles and conventional control ergo seat and by radio-control.
- Supply and installation of weighing systems for cranes.
- HVAC systems.

SERVICES ON PLANT

Our qualified technical team offers corrective maintenance service, preventive maintenance, repairs, start-up in the client facilities, adapting us to the client's needs and requirements.

We offer our clients all kind of services in plant:

- Supervision of the assembly in plant.
- Execution of SAT tests and put into service.
- Preventive, predictive and corrective maintenance works in equipments.
- Diagnosis and solution to breakdowns.
- Modification on existing equipments.
- Modernization of equipments (Retrofitting).
- Training for the maintenance personnel.
- Post sales service.

ACTIVITIES AND REFERENCES

Coapsa has become an essential reference in the nuclear field, that is why most of Spain's power plants and their service companies trust Coapsa as a provider of goods and services.

Works on nuclear field

- Trillo NPP: Completely remodelling the 404TN gantry crane in the turbine hall and undertaking a series of improvements to the polar crane. There is constant support work throughout the year, especially during recharge times.
- José Cabrera NPP: Complete reformation of the Omega gantry crane in the containment building in order to meet the requirements established for the handling of the spent fuel casks.
- Vandellós NPP: Manufacturing of the local command cabinets for the new essential services water cold source. Continuous maintenance and enhancement work on the plant gantry and fuel handling cranes at the plant.
- Ascó NPP: Installation of two new 115TN carriages and integral reformation of the bridge cranes at the fuel buildings in order to reach compliance to the Nureg-0554 regulation for spent fuel cask handling. Installation of a radio control system for polar crane handling. Continuous maintenance and support work.
- Almaraz NPP: Adaptation to the Nureg-0554 and Nureg-0612 Appendix C standards of the two bridge cranes located at the fuel handling building.
- Almaraz NPP: Study, design, materials supply and installation of the renovation and adaptation of the control of the crane ATRX, GVX-AR

• Almaraz NPP: Study, design, materials supply and installation of the renovation and adaptation of the control of the crane ATRX, GVX-AR

• Laguna Verde NPP (Mexico): Manufacturing and installation of a new 7,5TN Radioactive waste crane.

• Santa Maria de Garoña NPP: Amedment of the bridge crane from the reactor building adapting it to the Nureg-0554 and Nureg-0612 Appendix C standards, "Heavy Loads Control" and "Single Failure Proof Crane".

• Equipment control system design for the manipulator machine "Second Skip Handler Machine"





EQUIPOS NUCLEARES, S.A., S.M.E. (Ensa)

Avda. Juan Carlos I, 8
39600 Maliaño (Cantabria)
Tel.: +34 942 200 101
E-mail: commercial@ensa.es



Equipos Nucleares, S.A, S.M.E. (Ensa) was established in 10th July 1973 with the purpose of meeting the demands of the Spanish civil nuclear manufacturing of large components. The construction of the facility, located in Maliaño (Cantabria), south of the bay of Santander and very close to the city, was performed during 1975 and 1976, when the manufacturing operations of the first equipment for the Spanish market started.

Especially focused in the civil nuclear industry, Ensa obtained its first ASME nuclear certification in 1978 delivering the first component, the reactor vessel for Valdecaballeros Nuclear Power Plant, in 1981.

In 1980, with the creation of the Business Development & Field Services department, Ensa started performing works such as installation, commissioning, fuel management, plant maintenance, decontamination and



dismantling at nuclear power plants. Since 1986 Ensa has a majority ownership of ENWESA, a company mainly dedicated to providing services at nuclear power plants.

Since the beginning, Ensa has had the infrastructure, technology and human resources necessary to meet the highest standards in the areas of engineering, design, procurement, quality assurance, manufacturing, inspection and services. Ensa's facility includes a workshop, capable of manufacturing the biggest nuclear components, and an Advanced Technology Centre (ATC) for the development and qualification of innovative manufacturing and inspection techniques. The ATC also incorporates accredited laboratories that can provide services both to Ensa and to external customers.

Known in the nuclear industry as a preferred manufacturer thanks to the high quality and technology of its products and manufacturing processes, Ensa specializes in components such as reactor vessels, including internals, supports, reactor vessel cover heads, steam generators, primary circuit piping, pressurizers, heat exchangers, nuclear fuel element top and bottom nozzles, spent fuel casks, for storage and transport, fuel racks, for both new and used nuclear fuel, components for the ITER project (International Thermonuclear Experimental Reactor), and more recently on advanced, new generation and small reactors.

Since its inception, Ensa has provided equipment, operating to the required safety levels in nuclear plants of multiple and varied designs located throughout the world, following recognized international standards and meeting the most demanding quality requirements.

This has made Ensa a distinguished multisystem manufacturer, capable of successfully providing the most demanding nuclear components, through continuous research and development of new and competitive manufacturing technologies, for each of the different nuclear designs in the market.

The company has its premises and headquarters in Maliaño, Cantabria, Spain. It belongs to the SEPI Group, a public business holding that owns directly, or in majority, a total of 15 public companies, with more than 78,000 professionals. It also has a supervised public foundation and direct minority shareholdings in other nine companies, plus indirect participation in more than one hundred societies.

ENSA'S INTERNATIONALIZATION

With technology and quality as the main pillars of the company, the successful orientation towards the international market started in the late eighties. Nowadays exports over 90% of the manufacturing of heavy equipment, in addition to the provision of services to plants. Ensa is involved in demanding markets such as in France, Belgium, Japan, China, Taiwan, Slovakia, USA, England, etc. Currently, all major equipment being manufactured in Ensa have a destination in the international market.

Focusing only on the NSSS (Nuclear Steam Supply System) components, only three of the thirty-seven major components manufactured by Ensa until 1986 were made for the international market, a percentage lower than 10%. However, this situation changed significantly in the late Eighties, when a rapid increase in exports began. Twenty-six large components were

Turnover	74.28 million €
Exports (2020)	69% of sales
Average Staff (2020)	479 employees Ensa + 195 employees Enwesa
Specialized operators	53% and 47% engineers and technicians
Average age	43 years (Ensa + Enwesa)



exported between 1988 and 1995. Although the Spanish market demand, a priority for Ensa, restarted in the mid-nineties, due to the need for replacement components in operating power plants, only three components of a total of eighty-eight have been provided to this market since 1997. This means that the internationalization has represented about 96% of Ensa's portfolio since 1997.

Regarding Fuel Management business, Ensa has also provided transportation and storage casks for fresh and used fuel to countries like China, Japan and the U.S.A. as well as storage racks for nuclear fuel pools in South Korea, Germany, South Africa, Taiwan, Finland and China. For both casks and racks Ensa offers an integral solution based on competitive designs, in which lessons learned, as an experienced manufacturer and operator, have been incorporated, resulting in designs such as the ENUN 32P, ENUN 52B and ENUN 24P casks.

Ensa has maintained a constant activity in other areas, such as design and services, which have also undergone a strong internationalization. Examples of this internationalization include the outstanding participation of Ensa in the South African project PBMR (Pebble Bed Modular Reactor).

Reactor), participation in IRIS (International Reactor Innovative and Secure), ITER project and provision of services in nuclear plants in countries such as Bulgaria, Finland and France.

Another important market line is the dismantling of national and international nuclear power plants. It's important to highlight the works carried out at José Cabrera (Guadalajara), Vandellós (Tarragona) and Kozloduy (Bulgaria) plants.

Throughout its history, the nuclear manufacturing activity in Ensa has also been compatible with the manufacturing of components for research institutes (CERN, UKAEA, EPRI, Max Plank etc.) and institutions (ITER, NASA, EURATOM). Additionally Ensa has manufactured offshore oil platforms, support services to other firms and pressure components for the chemical and petrochemical industry.

HUMAN TEAM AND COMPANY KEY FIGURES

Ensa currently holds ASME accreditations (N, NPT, NA, N3 and NS, stamps), ISO 9001, ISO14001, ISO/IEC 27001, ISO 45001, UNE 166002 and OSHAS 18001, TÜV DIN, TÜV AD 2000-Merkblatt. Ensa holds ENAC ISO / IEC 17025 accreditations as well, for its metrology laboratory and its destructive test lab, located in the Advanced Technology Centre.

Ensa's competitiveness is based on its highly qualified and competent staff and their culture and passion for improvement, safety, quality, innovation, research and technological development.

The current book order includes the supply of equipment and services to countries like France, USA, United Kingdom, Italy, Argentina, Brazil and Spain.





Konecranes is a world-leading group of Lifting Businesses™, serving a broad range of customers, including manufacturing and process industries, shipyards, power plants, ports and terminals. Regardless of your lifting needs, Konecranes is committed to providing you with lifting equipment and services that increase the value and effectiveness of your business.

With over 50 years of experience in the nuclear industry and as a member of the ASME NOG-1 committee that sets the standards for the design of lifting equipment in nuclear facilities, Konecranes can expertly provide all equipment, services and equipment upgrades. Handling of nuclear materials around the world. Thanks to its technical service network spread over more than 50 countries, it can service equipment from any manufacturer within nuclear power plants, fuel processing facilities and nuclear waste storage facilities, including safety-related lifting equipment plus review.

EQUIPMENT

Cask handling crane

These specialized cranes utilize Konecranes latest generation of SUPERSAFE™ single failure proof technology to safely and efficiently move nuclear spent fuel.

Our continuous research and development program employs the latest cutting edge technology, while maintaining a core technology that is based on time-proven nuclear designs. Konecranes engineers understand the complexity of nuclear cask handling, and the importance of coordinating precision operation, safety and reliability.

Cask Transporters

The latest generation of Konecranes spent fuel nuclear cask transporters are designed to safely and efficiently handle most nuclear dry storage casks. To provide you with a high level of safety, load drop protection is standard, and the ergonomic controls simplify operation. Our transporters are available in both rubber tire and track-driven designs capable of handling up to 350 tons and offer the smallest possible turning radius, including full rotational capability. They can be easily shipped to locations worldwide in standard shipping containers and are specially designed for simple assembly in the field in just one day.

Fuel Handling Equipment

Konecranes nuclear fuel handling equipment utilizes SUPERSAFE™ single failure proof technology, which is designed to comply with stringent worldwide nuclear regulatory requirements. Key safety and diagnostic

systems continuously monitor equipment operation, which is displayed to the operator in real-time graphics.

Nuclear Polar Cranes

Our latest evolution of polar cranes utilizes a multipurpose design that maximizes operational capability by combining numerous lifting features into a single compact and weight-efficient trolley. The design improves productivity and reliability by providing four primary lifting systems including a main hoist, auxiliary hoist, maintenance jib crane, and containment inspection man lift, all conveniently located on one trolley.

The polar crane main and auxiliary hoists are designed to perform typical plant maintenance and operational functions, and both hoists can be provided with a single failure proof or non-single failure proof design.

To facilitate multipurpose lifting, a maintenance jib crane is typically mounted on the main trolley, designed to provide lifting capability during maintenance operations of the entire polar crane. This reduces the need for cumbersome lifting equipment that is typically provided by the customer's plant on a temporary basis to complete polar crane maintenance.

Turbine Cranes

Konecranes has supplied more than 100 large turbine hall cranes to nuclear power plants as well as hundreds of these types of cranes to non-nuclear power plants. Konecranes turbine hall cranes include many design features to improve performance such as on-board diagnostics, precise positioning and remote operator's controls.



Net sales	3,179.9 million €
EBITA	8.2%
Locations	More than 600
Countries network	More than 50
Personnel	16,860

We also understand the importance of the bottom line so we provide one of the most weight efficient designs in the industry, which not only reduces the initial cost of the crane but also reduces the cost of the crane support structure. For those applications where the highest degree of safety is required, we offer our SUPERSAFE™ single failure proof design, which includes the most advanced safety features in the industry.

Heavy Lift Hoists

The Hevi-lift hoist has a history over 80 years and is widely used in the nuclear industry. It is known for its long life, quiet operation, superior strength and quality.

The Hevi-lift hoist makes a perfect choice for nuclear containment as it is made out of materials suitable for all reactor types. Hevi-lift hoists are manufactured with a minimum amount of deleterious materials, such as aluminum and zinc. The Hevi-lift hoist is also available as a NUREG-0554 compliant single-failure-proof model.

SERVICE

Konecranes is uniquely qualified as a provider of service and parts to the nuclear industry. A distinct advantage we offer our customers is the ability to provide service on a worldwide basis.

With 600 locations worldwide, we can provide a response that is fast and efficient. Whether you need outage support, routine maintenance, engineering support, or anything in between, we have people you can rely on.

The ability to complete modernizations and supply parts to the nuclear industry requires compliance with stringent regulatory and quality requirements. We have the capability to provide parts and service in compliance with these standards with our audited and approved nuclear quality control program. As a global company, Konecranes can help you

stay compliant with local requirements with the combination of industry experts and localized know-how.

Our parts are supported by ISO 9001 certified manufacturing that employs KTA-1401 and ISO 9001 quality control programs, a seasoned nuclear engineering group, warehouse and distribution facilities as well as critical-mass purchasing power.

Modernizations

We have completed many modernizations at nuclear power generation facilities and our technicians routinely modernize both our own and other manufacturers' equipment.

Modernizations can include:

- Single failure proof upgrades
- Crane and runway capacity upgrades
- Duty-cycle studies
- Planned engineered lifts
- Diagnosis and solutions for tracking problems, abnormal rail/wheel wear and fatigue cracks
- Control Upgrades – Variable frequency, static stepless or DC-Digital
- Festoon system replacement
- Integrate load cells/weight systems
- Replace motors, brakes, magnetorques

REFERENCES

- Loviisa Nuclear Power Plant Finland - 16 ton ILW Gantry Crane
- The ISF at Magnox Bradwell - 29t x 23.01m spam Demag Automated EOT Crane

- The ISF at Magnox Harwell - 55t x 27.1m spam Demag Manual EOT Crane
- Babcock International Group's Rosyth - 32/5t x 51,32m spam Konecranes Gantry Crane at Dockyard engaged in Submarine Dismantling
- Bremerton and Bangor WA. 2016 – 2019 - 4 x 25 ton Portal Jibs
- Portsmouth, ME. 2018 - 1 x 140 ton Nuclear Rated Portal Jib
- ACOE LA. 2019 - 1 x 60 ton Portal Jib
- Bremerton 2019 - 1 of 7 Nuclear Rated Portal Jibs
- US DoD - 900t x 19.457m (o/all width) Rubber Tyred Gantry Crane
- Cofrentes (Spain) - 80t Crane uprated to 125t
- First Energy – Inspection Agreement the all cranes of the plant and perform outage support
- PSE&G – Salem and Hope Creek – Site Contract Ejection of modernizations, Maintenance and inspections. Support at stops.
- Exelon. Modernization of recharge equipment - Hevi-Lift hoists in numerous locations.
- Zion (Dismantling) Maintenance to keep the fuel crane worn during pool discharge.
- Dairyland (Dismantling) Drafting of inspection protocols and operating instructions. Performing maintenance to keep the fuel crane worn during pool discharge.
- Waterfall (Sweden) Inspection and maintenance of the reload crane, engineering analysis of all reload cranes and modernization of all outage cranes.





NEWTESOL S.L. started operating with the aim to support Spanish nuclear civil program demands. The company headquarters is located in Santander (north of Spain) and brings decades of experience in welded manufacturing and Weld overlay.

Since its foundation, Newtesol has invested both in technological innovation and human capital, which has allowed the organization to provide high added value solutions to its customers and to be positioned as an international benchmark in the welding industry.

OUR TECHNOLOGY

Newtesol is committed to technology and continuous improvement as the right path to reach the operational excellence.

With the aim of improving the quality of the weld overlay in the nuclear industry while ensuring competitiveness in the market, the company has developed a fully automated TIG/GTAW welding process pushed to its theoretical and technical limits. This technology ensures high productivity and efficiency in the process and deposition rates that allow it to compete economically with other processes, such as submerged arc welding (SAW), while providing much higher levels of quality in its products.

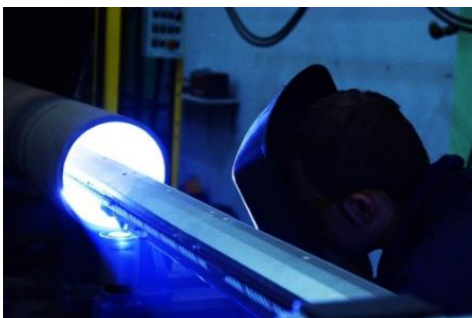

The company has currently the latest welding technology and continues to develop new prototypes to face the upcoming challenges in the industry. Besides its internal developments, which are part of its added and differential value in the industry, Newtesol continuously develops new welding technology in partnership with the leading machine manufacturers in the market, or with the University and its research centers.

Industry 4.0

Newtesol is committed to information technologies and the power of data as the only way to face the new demands in the industry in an increasingly competitive market.

The company has developed a data acquisition system in its welding machines and personnel presence monitoring in their facilities. This system allows to analyze parameters and automate works to ensure the optimization of the production in real time.

PRODUCTS

Newtesol has extensive experience in the manufacture of all types of nuclear components up to 50 Tm. The scope of production includes the following products:

- Steam generator internals, such as cyclones, rings, supports or complete swirl vane separators.
- Spent fuel rack components
- Radioactive waste containers
- Tanks and pressure vessels
- Heat exchangers
- Weld overlay on tubesheets and other special parts
- And much more (covers, valves ...)

Since its foundation, the company has increased its product portfolio, being currently an international reference in weld overlay for the Oil & Gas onshore and offshore-subsea, as well as a key player for the defense industry in the manufacture of critical submarine parts.

Turnover (2020)	12,15 million €
Exports	84% of sales
Staff	74 employees
Specialized operators	100% (27% Engineers)
Average	35 years

OBSESSED WITH QUALITY

Newtesol is committed to quality both in the project management and in the final product as a key factor of its organization. The company promotes a corporate culture of "zero defects".

Certifications and codes

- ASME Nuclear Quality Assurance (NQA-1)
- ASME III NCA-3800
- ASME III Design and manufacturing
- Sello U, ASME VIII Div.1
- Sello U2, ASME VIII Div. 2
- Sello NPT, ASME III Div. 1
- RCCM, Quality level Q1
- API-5LD monogram
- DIN-EN 729-2 UNE EN-3834
- 10 CFR 50 App B y 10CFR21
- ISO 9001
- ISO 14001

SERVICES

The high qualification of its professionals together with their extensive experience in the industry, ensures the optimal service for the customers in the different phases and project areas:

Technical advice

Technical resolution of the most complex projects with the strictest quality requirements.

Design

Extensive experience in equipment design under ASME III, ASME VIII Div.1 and Div.2 standards.

Purchasing and material upgrade

The company provides a large network of contacts for the purchase of the most specific material. In addition, Newtesol is certified for material upgrading to ASME III for in-house manufacturing under ASME III NCA-380.

Document management

The proper issuance of the project documentation is one of the keys to ensure the quality of the final product. The company places a high value in the detailed planning and management of all the project documents by an expert and dedicated team.

INTERNATIONAL RECOGNITION

In addition to the projects focused on the maintenance of the Spanish nuclear power plants, Newtesol is a major player and has extensive experience in various international projects for nuclear power plants in countries such as United States, Finland, France, Slovenia, the United Kingdom, Taiwan and China, among others.

As a result of this experience, Newtesol is recognized internationally and by the main nuclear organizations, such as the "World Nuclear Exhibition", where it has been awarded the prize for "Operational Excellence" in its 2018 edition.



Headquarters
Aravaca, 6-8. 3rd
28040 Madrid
Tel.: +34 915 359 640
E-mail: nusim@nusim.com

Balbino Marrón 8, 6^o
Viapol Building
41018 Seville
Tel.: +34 954 932 447
E-mail: ingenieria@nusim.com



40Tn Handling equipment for Ondraf/Niras IPM (Installation for the production of monoliths) in Belgium

NUSIM, S.A., was founded in 1980 to provide technological solutions for different application fields, such as Nuclear, Health Care, Research, Construction and Prevention.

Nowadays, NUSIM, S.A. consists of four divisions: Radioactive Waste Treatment, Radiation Protection, Health and Safety Instrumentation, and Automation, all supported by their corresponding Maintenance Areas.

These divisions provide high quality products and services to a wide range of clients, including Nuclear Power Plants, Official Organizations (ENRESA, CIEMAT), Hospitals, Universities, National Laboratories, and other specialized industries.

NUSIM, S.A. has a Quality Assurance system in accordance with the requirements of the UNE 73401:1995, UNE 73402:1995, ISO 9001:2015, ISO 14001:2015, and radioactive national nuclear industry certifications GES and regulator certification ENRESA.

SERVICES, PRODUCTS AND TECHNOLOGY AVAILABLE

RADWASTE TREATMENT DIVISION

The Radioactive Waste Division, with over 35 years of experience working with all the Nuclear Power Plants in Spain, carrying out the Engineering, Manufacturing, Commissioning, Operation and Maintenance of equipment for treatment, handling and transport of Radioactive Waste.

NUSIM has developed a significant number of equipment that are being used today in all the Spanish Nuclear Power Plants in operation or decommissioning and in the Official Spanish Agencies and disposal, like ENRESA (El Cabril) or research centers like CIEMAT.

NUSIM is also internationally present with equipment in main nuclear sites like Laguna Verde NPP (Mexico), Kozloduy NPP (Bulgaria), Karachi NPP (Pakistan), Chernobyl NPP (Ukraine), Atucha NPP (Argentina), the NORM waste treatment plant (Abu Dhabi) or Ondraf/Niras IPM in Belgium.

All the equipment developed by the Division are manufactured on the basis of own technology. The proposed solutions have been developed to meet the most demanding requirements, giving reliability and robustness, which is highly valued within the Nuclear Sector.

The products range covers the hole cycle of the Radwaste from cradle to grave.

Equipment catalogue features:

Handling Devices of Drums, HICs, Containers and special Handling with filling, capping, or nesting process.

Inspection Equipment

- X-Ray Drums Inspection.
- Sampling systems.
- Latency reactor Inspection equipment.

Radiological Characterization for radwaste packages (drums or containers) with accessories for capping, surface contamination test etc.

Processing Equipment for recovery and reconditioning Plant for Historical Wastes.

Volume Reduction Equipment

- Drying systems for sludge or miscellaneous waste by microwave or resistances.
- Pre-compacting equipment.
- HEPA filters Compactor

Grouting and cementation systems

- In situ Mixing System or premixed systems.
- Modular Blocking System, skid or ISO container mounted systems.
- Continuous or batching Mixers with cleaning system.
- Secondary waste recovery systems.

Cleaning and Decontamination Equipment

for drums or containers in fully enclosed cabinet, on conveying line or in glove box.

Transport Equipment ADR (American Depository Receipt)

Vehicles and packaging ADR for radwaste land/air transportation.

Decommissioning equipment and Systems.

Cutting, confining handling, water treatment, processing.

Waste recovery. Extraction cut and decontamination of tubular bundles of heat exchangers.

NORM radwaste facilities with integral solution for processing, drum filling capping, nesting, cementation and grouting.

RADIOLOGICAL PROTECTION DIVISION

Since its creation, NUSIM is the exclusively distributor in Spain of equipment for contamination measuring, spectrometry systems, dosimetry systems and equipment, and electronic components

Founded in	1980
Exports	27%
Sales that comes from the nuclear and radwaste sector	76%
Master Degree Engineers	70%

for the detection and measurements of the Ionizing Radiation from the main Companies: Mirion – Camberra and ORTEC among others.

This Division is not only in charge of distribution, but also of assembly and onsite commissioning to products for Nuclear Power Plants, Research Centers, Universities, etc. undertaking the subsequent maintenance to ensure proper functioning.

The catalogue features the following equipment:

- Radiation Dosimeters.
- Spectrometry Alfa and Gamma.
- Contamination Monitors equipment/ clothing.
- Personal Contamination Monitors.
- Radiometer/ Radiation Meters.
- Portal monitors for trucks/vehicles.
- NaI y LaBr3 detectors.

AUTOMATION DIVISION

Carries out the study, the planning and the integrated global solutions for the automation systems covering the design, development, assembly and commissioning in all type of industry installations.

NUSIM carries out the PLC's and SCADAS programming of the main manufacturers in the market. NUSIM is recognized integrator of Rockwell Automation even though also have tools and knowledge of the software of the main brand in remaining market shares such as Siemens, Schneider, Omron, ABB, etc.

NUSIM integrates complete automatic systems, both hardware and/or software from different manufacturers, interconnecting business systems (ERPs, Information Servers, etc.) with the manufacturing (Solutions MES).

OUTSTANDING NATIONAL AND INTERNATIONAL ACTIVITIES

RADWASTE TREATMENT DIVISION

Between main references, the major projects are the following:

- Container handling, nesting and capping equipment for the New Safe Confinement in the Chernobyl NPP, Ukraine (TAIM WESER).
- Stabilization and Solidification plant for NORM ashes. ADNOC Abu Dhabi National Oil Company (TAKREER).
- ISO container SAS confinement with control room for the José Cabrera NPP reactor vessel lid cutting.
- Drums and HIC handling and compaction equipment for Laguna Verde NPP (Mexico).
- Reprocessing Plant for Historical Waste, for the Santa María de Garoña NPP.
- In drum Microwave Drying Facility, for Ascó and Cofrentes NPP.
- Equipment for Casting Collection and Cooling for a Plasma Oven Facility for Kozloduy NPP (Bulgaria).
- Miscellaneous drum drying facility by heating resistors for Asian NPP.
- 7 Handling equipment for Ondraf/ Niras IPM in Belgium, up to 40Tn load capacity.
- In addition, drum and container handling devices, waste solidification plants, package radiological characterization systems, compactors, etc. are in operation in all the Spanish nuclear emplacements.
- NUSIM has developed new equipments for tilting of drums, automatic manipulators for forklifts, in-drum precompaction with recoverable sleeve, radiological inspection system of roads all with the new technology of augmented reality.

RADIOLOGICAL PROTECTION DIVISION

Main supplies during recent years:

- Body Count Contamination Monitors: Mirion Technologies and RADOS with proportional and scintillation detectors for Trillo, Almaraz, Ascó, Vandellós II, Cofrentes and Santa María de Garoña NPPs and El Cabril.
- Handfoot RADOS contamination with proportional and scintillation monitors for Almaraz, Trillo and Ascó NPP and El Cabril.
- Laundry RADOS monitor for NPPs: Ascó, Almaraz, Vandellós II and Santa María de Garoña and for tools for Vandellós II.
- TLD RADOS dosimetry systems: Almaraz, and Trillo NPPs and Dosymetry center.
- Gamma Spectrometry Systems ORTEC with germanium detectors and Alpha Spectrometry Systems ORTEC for Polytechnic Universities of Valencia, Cáceres, Basque country, Barcelona; Catalanian Government, CIEMAT and CSIC.
- Portable Gamma Spectrometry Equipment ORTEC for ENRESA, Customs Algeciras and Catalanian Government.
- BrLa y NaI detectors for environmental network of the Catalanian Government.
- Integral radiological protection equipment for the NORM waste treatment plant. Takreer, Abu Dhabi.



Handling Equipment for Drums, El Cabril (ENRESA)

Polígono Industrial Empresarium
C/ Romero, 6
50720 Zaragoza
Tel.: +34 976 454 940
E-mail: ringo@ringospain.com



Ringo Válvulas S.L (RV) was founded in 2000 with the aim of manufacturing high performance valves of all types along with operational spares for use in the nuclear industry. Thanks to a team of persons with over 35 years of experience in valve manufacturing for the nuclear industry, RV currently has over 90% market share for the Spanish nuclear power plants, along with numerous contracts to supply to more than 45 plants in 20 different countries: Spain, Sweden, Finland, Switzerland, Belgium, United Kingdom, Russia, Belarus, Bulgaria, Slovakia, Slovenia, Ukraine, Rumania, South Africa, China, India, Mexico, Argentina, Brazil, Canada and USA.

BUSINESS OBJECTIVE

The business objective of RV has, and continues to be, to cover the demand of the Spanish nuclear industry for valves and spares, guaranteeing equipment supply and providing high levels of quality and reliability. RV is equipped with modern facilities adapted to the manufacturing needs of the Spanish nuclear market, and is capable offering a rapid and satisfactory response to its clients' demands.



Thanks to good supply experience and excellent technical references, RV has been able to access the nuclear valve export market, this having increased its backing and commitment to the nuclear sector and leading the company to consolidate a professional team with wide experience on the nuclear market.

The RV plant is a modern facility with the latest technology available for all manufacturing activities. Plant is located in in the Empresarium industrial estate in Zaragoza's most modern and logistically best located industrial zone. Production facility has a manufacturing area of 12,000 m2 and office space of 2,500 m2.

SERVICES, PRODUCTS AND TECHNOLOGY AVAILABLE

RV manufactures all types of valves for the nuclear industry, both nuclear and non-nuclear class. Applicable design codes are ASME III, NB, NC and ND, AD-Mekblatter and RCC-M.

Ringo portfolio includes:

- Gate valves: both manual, motor-operated and pneumatic.
- Globe valves for on/off services and regulation.
- Control valves.
- Check valves, including testable and assisted valves.
- Butterfly valves for applications such as containment and control room isolation.
- Diaphragm valves.
- Bellow seal type zero leakage valves.
- Ball valves, including top entry and in-line removable types.

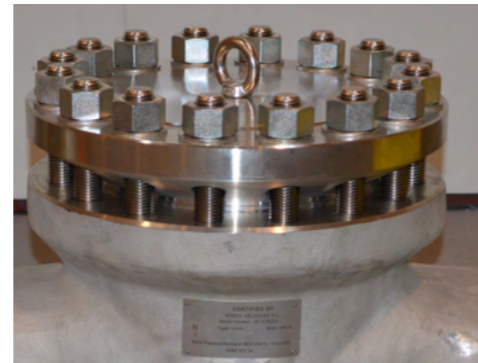

RV supplies solutions with ON/OFF and control valves for applications such as: Main Steam Isolation, Main Steam By-pas, Feedwater, Spray Pressurizer, Pressurizer relief, Turbine By-pass, MOV for depressurization or Turbine Steam extraction.

RV has a Quality system in accordance with ISO-9001-2015 and it is homologated in accordance with the European Pressure Vessels Directive 2014/68/UE for the manufacturing of valves and related spares. On the other hand, RV is a company qualified as ASME III N & NPT stamps holder that allows RV to supply nuclear valves for the plants in USA and even has been recently approved by ASME as Material Organization.

Besides the main target of assuring the quality of its products, RV is fully committed to the environment, safety and corporate responsibility so, in order to fulfill all these aims, RV has an environmental program certified according to ISO 14001, a safety system qualified to the ISO 45001 and a corporate responsibility program certified as per SA8000.

RV is approved for some of the most relevant plant designers such as Westinghouse, Siemens, Areva, GE Hitachi, KHNP-Kepeco, NIAEP-JSC Atomenergoproekt or NIAEP-JSC

Turnover average	47 million €
% of sales related to nuclear products	32%
% of sales related to nuclear products in the Spanish market	35%
Staff	120 employees
Graduates and highly qualified technical staff	60%
Specialist operators	25%
Administrative personnel	15%

Atomenergoyexport. On the other hand, RV is also approved by the following end users: Grupo de Propietarios de Centrales Nucleares Españolas, Comisión Federal de Electricidad (Méjico), NASA (Argentina), Electrobras (Brasil), Grupo de Propietarios de Centrales Nucleares Suecas, NOK (Suiza), Electrabel (Belgica), Fortum (Finlandia), Comision Nuclear de Rumania, Rosenergoatom (Rusia), RUE Belarussian (Bielorrusia), TAEK (Turquía), NPC (India), CNNC (China), KHNP in South Korea, OPG and Bruce Power (Canada) and Tenesse Valley Authority (USA).



RV has the most advanced design software in both 2D and 3D, allowing calculation in all areas, mechanical, fluid and dynamic noise, ensuring the adequacy of the valves. This is very important, especially in control valve applications for critical services.

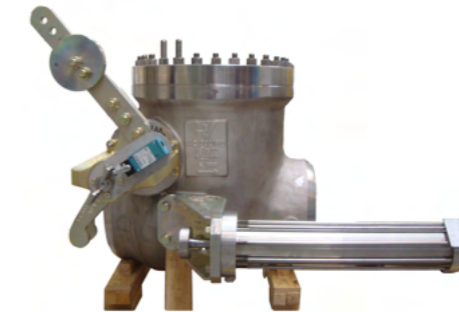

ACTIVITIES AND REFERENCES

In spite the pandemic situation generated by COVID-19, Ringo Válvulas has been steadily providing service to its customers, including the lockdown period when only the essential services were able to continue their activity. Ringo Válvulas was considered as an essential service by the authorities, thanks to the action of the Spanish Nuclear sector that identified Ringo as a supplier of essential equipments. In that way, Ringo could continue with all the activities for the manufacturing of valves and spare parts for the Spanish Nuclear Power Plants. Finally, all the outages were successfully completed in spite of the pandemic challenges.

In the international Market, the most relevant milestone achieve by Ringo during 2020 was the signature of a representation contract for the North American nuclear market that has allows the reception of several orders for Bruce Power, Pickering and Darlington in Canada as well as for Watts Bar in USA. These contracts include the supply of Gate, check, Bellow Sealed Globe and Ball valves in different classes up to nuclear class 1 and N-Stamped according to ASME III. Some of the cases, valves have been already supplied.

All the achievements stated above are based on the Ringo philosophy, absolutely oriented to the design and manufacturing of the products in fully accordance with the requirements of codes and client specifications of each particular project. For that purpose, Ringo Válvulas has specific training programs for its staff, with special focus on nuclear safety culture, where the proper working procedures are established and personnel is motivated to be totally committed to that culture.





TAIM WESER, S.A.

Carretera de Castellón km. 6,3
50013, Zaragoza
Tel.: + 34 976 500 006
E-mail: info@taimweser.com

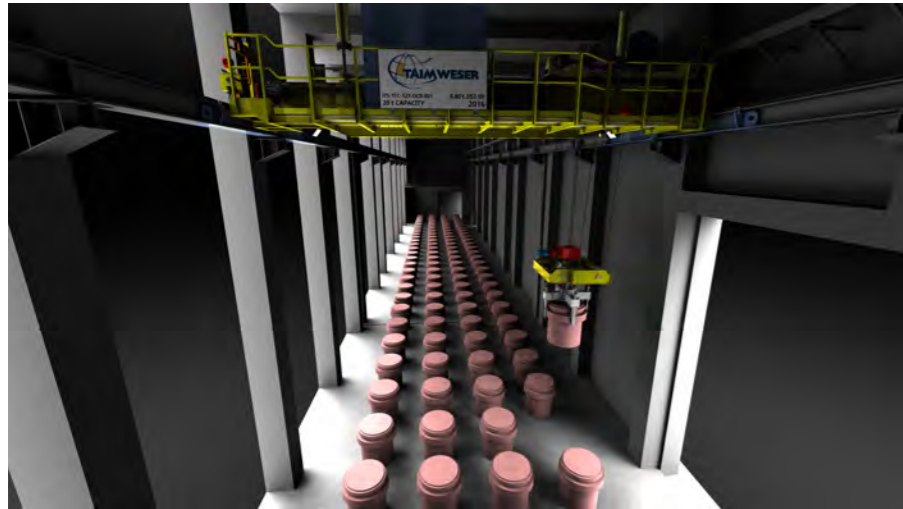

At **TAIM WESER** we have more than 120 years experience in the supply of tailor made EOT and gantry cranes as well as turnkey bulk materials handling installations for the main industrial sectors, according to the specific requirements demanded by our customers and always based on the principles of safety, high performance, precision of movements, low maintenance and operation costs and maximum availability of our products.

We are a major solutions provider for the nuclear industry supplying tailor made equipment for the handling of low and intermediate active nuclear waste and nuclear fuel in New Build as well as Decommissioning projects of Nuclear Plants.

In addition, we have also supplied high precision cranes to the most prestigious research experiments in the world, CERN and CELLS studying the relation between mass and energy.

We are qualified supplier of ENRESA, IHI, ELECTRABEL and SELLAFIELD among others and we are certified ISO 9001, ISO 14001 and ISO 45001.

SERVICES, PRODUCTS AND TECHNOLOGY AVAILABLE

Turnkey supply of cranes and bulk materials handling installations

We specialize in the supply high integrity in cell and out cell EOT cranes, gantry cranes and trolleys as well as single failure proof (SFP) equipment to perform critical load-lifting applications as the handling of low and intermediate active nuclear waste as well as nuclear fuel. In addition, we also supply high performance stockyard machinery and conveyor system for the handling of raw materials as uranium ore. For this purpose we have the most suitable resources and the most advanced techniques. Our scope of supply includes the whole project cycle, design, manufacturing, assembly and test at our facilities, final assembly at site and commissioning of the equipment.

All essential processes of design and fabrication are carried out and supervised in our installations and additionally all the cranes are assembled and tested in our factory, generally without load, or with load if required by the customer. This process leads us to the achievement of a high quality final product and an absolute assurance that no major unforeseen problems will happen during site's installation.

After sales and spare parts

Our after sales service provide our customers with its extensive experience and know-how in maintenance service, improvement and revamping of equipment and complete facilities.

Our high-qualified staff is able to provide the optimal solution to the client's requirements. For this purpose, we have the suitable resources and the most advanced techniques through our specialized team in engineering development, erection and commissioning.

On demand, our customers can hire us to enjoy a wide range of services, shaping up the pattern that fits best their needs. These services focus on different areas, as follows:

- Ad hoc maintenance and service works.
- Inspection of TAIM WESER or third parties equipment.
- NDT: Non Destructive Tests.
- Reverse engineering.
- Structural analysis.
- Customized solutions.
- Facilities revamping.
- Specific purpose training.
- SWP (Safe Working Period) and Exceptional Inspections, fulfilling the UNE 58144-5:2015 standard

In addition, besides supplying top quality commercial parts made by first class suppliers, we manufacture in house in our hi-tech facilities a wide range of components, thus ensuring the best product to our customers.

We secure all components interchangeability, according to client's strictest integration requirements.

Maintenance services and technical assistance

More than a service, we provide security, reliability and protection to our customer's assets. A well-managed, planned and executed maintenance is essential to optimize resources:

- Extension of equipment operation life.
- Reduction of down-times and their associated costs because of the non-production.
- General OPEX reduction.
- Improvement of equipment performance.
- Fulfilment of targets set in the operation plans.

Founded in	1899
Turnover 2019	50 million €
International Activity	98%
Offices and agents	Through 20 countries
Projects developed	In over 70 countries
Staff	350 employees
% of superior degree holder employees	60%



OUTSTANDING ACTIVITIES- NATIONAL

- Supply of EOT cranes to the first Nuclear Power Plant installed in Spain, José Cabrera NPP.
- Supply of EOT and gantry cranes to Vandellós I NPP.
- Supply of EOT and gantry cranes to Ascó I NPP.
- Supply of EOT cranes to Trillo NPP.
- Supply of EOT and gantry cranes to El Cabril low and intermediate active nuclear waste repository.

OUTSTANDING ACTIVITIES- INTERNATIONAL

- Supply of EOT crane to Atucha NPP, Argentina.
- Supply of EOT crane to HABOG repository for high-level nuclear fuel disposal, located in the Netherlands.
- Supply of EOT and gantry cranes for the assembly and lowering of the CERN's LHC particle accelerator in Switzerland.
- Supply of EOT crane to Berkeley NPP, UK

- Supply of EOT crane to Dounreay NPP, UK.
- Supply of EOT crane to Pilgrim NPP, UK.
- Supply of EOT crane to Sellafield NPP, UK.
- Supply of EOT crane to Rokkasho Aomori NPP, Japan.
- Supply of a SFP (Single Failure Proof) trolley to Tihange 2 NPP, Belgium.
- Supply of a bridge crane for handling of structure elements and RAW containers in the Technological Building (TEC) of the Chernobyl NPP New Safe Confinement (NSC) project.
- Executing a project for the supply of up to 24 out cell high integrity cranes for Sellafield Ltd.
- Executing other projects that include high technological lifting solutions for the nuclear sector; we cannot disclose more details due to confidentiality reasons.

COUNTRIES IN WHICH THERE IS NUCLEAR ACTIVITY

Technical assistance contracts in several countries in Europe and Asia and commercial activity in Europe, America and Asia.

OTHER DATA OF INTEREST

In addition to the nuclear sector, at TAIM WESER we have a wide experience in the global mining, ports and metallurgical industries as well as oil & gas and fertilizers sectors, where we provide customized integrated high-tech solutions for bulk solids handling and special lifting projects.

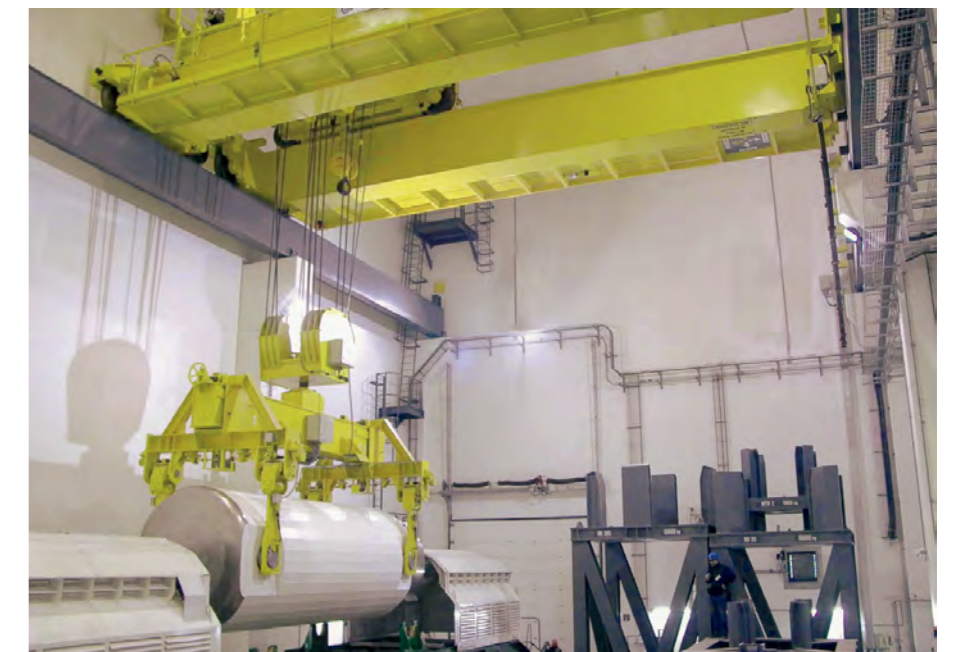



ENGINEERING AND SERVICES

—

Amphos 21
Empresarios Agrupados
Enwesa
GD Energy Services
Geotecnia y Cimientos, S.A.
Grupo Eulen
IDOM Consulting, Engineering, Architecture, S.A.U.
PROINSA
Tecnatom, S.A.
VIRLAB, Expertise in Vibrations and shocks. Testing Laboratory

64-83

—

The Spanish engineering and services companies have and continue to be engaged in nuclear projects across more than 40 countries.

Amphos 21 Consulting S.L.
C/ Venezuela, 103, 2º
E-08019 Barcelona
Tel.: + 34 935 830 500
E-mail: amphos21@amphos21.com

Amphos 21 Group S.L.
Paseo de la Castellana, 40, 8º
28046 Madrid
Tel.: + 34 620 634 729



Amphos 21 is a group offering an environmental consulting scientific, technical and strategic consulting services in 5 main activity areas:

- Nuclear
- Mining
- Water
- Sustainability
- Oil and Gas

We develop nuclear activities since our inception in 1994. Our team is recognised at an international level in radioactive waste management. From our headquarters, we work for clients in the entire world, mainly for agencies implementers and regulators of radioactive waste issues, the European Commission, as well as for private clients needing assessment on issues related with the uranium cycle, such as legacy wastes and soils affected by the presence of radioactive materials.

Our activities are organized around three main axis:

- Consulting
- R+D+i
- Advanced modelling solutions



Which we apply to provide the best solutions to the following issues:

- High, Intermediate and Low level radioactive wastes.
- Radioactive waste repository performance assessment and siting.
- Environmental and radiological impact of radioactive waste storage and disposal facilities.
- Water, sites and soils affected by the presence of radioactivity.

Our distinctive trends as organization are based on:

- A highly qualified team, used to face complex technical and scientific challenges to help our clients find the best solutions.
- Highly skilled in-house conceptual and numerical capabilities.
- Innovative solutions, which we present in international conferences and publish in international scientific and technical journals.
- Our imbrication with Universities and Research Institutions Worldwide, which puts us in a unique position to find and develop the best solutions for every case. There is a constant pool of Ph.D students and engineers advised by our senior staff.
- Our international character. Most of our activities in Nuclear are developed outside the Spanish borders (a 95% in 2020),

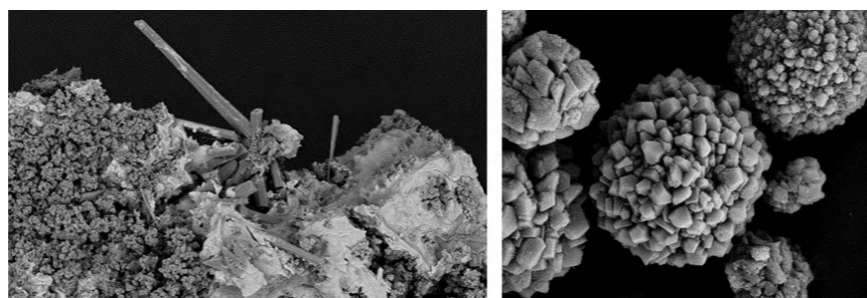

CERTIFICATIONS:

- Amphos 21 is certified according on international standards ISO9001 and ISO14001 and European Regulation EMAS.
- Amphos 21 is a company certified by the French Ministry of Education and Research (MENESR) as R+D developer (CIR).
- Amphos 21 is the 1st COMSOL certified consulting in geosciences.

DEVELOPMENTS 2020

2020 has been a special year worldwide. We, at Amphos 21 continued our service offering to all our clients, and also started new collaborations and activities, mostly at distance, as the times indicate. In the nuclear market, we developed around 100 projects for more than 20 clients in Europe (Spain, Sweden, France, Finland, Belgium, Germany, United Kingdom), in America (United States and Canada) and reinforcing our presence in Asia (Japan, Taiwan and South Korea). A turning point for Amphos 21 has been the integration into the RSK group towards the end of 2020, a consulting group for technical, engineering, and environmental services with more than 5,000 employees and with offices in more than 20 countries.

Below, we detail some of the activities that we developed in 2020, the ones that we consider most interesting as per their innovative profile within the sector and/or because of their strategic relevance to our business.

Founded in	1994, since 2020 integrated within RSK Group Limited
Annual revenue	14 million €
% of international activity	60% in general; 95% in nuclear
Total staff	Spain (founded in 1994); Chile (founded in 2009) and Peru (founded in 2012) 190 employees
% senior graduates	75%
% PhDs in Science and Engineering	11% in the group; 40% in nuclear

Within the framework agreement between Amphos 21 and the Swedish radioactive waste management agency (SKB), we have carried out numerous activities for the future spent fuel repository as well as for the medium and low-level waste repositories.

We highlight the modelling studies of the durability assessment of engineered barriers of the repository, underground water flow, transport of radionuclides, or chemical degradation of materials.

We have continued to support POSIVA, the Finnish Waste Management Agency, on its way to the implementation of the world's first-of-a-kind deep geological repository for spent fuel. Our activities have focused on bentonite barriers, the quantification of sulfides in the repository environment, and studies of groundwater flow and radionuclide transport in the geosphere.

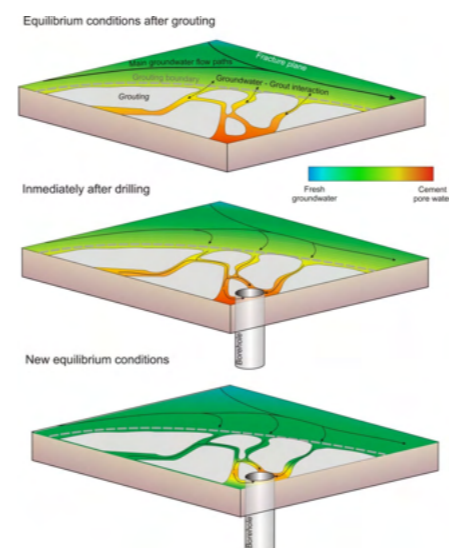

During 2020 we reached an agreement with the Belgian Waste Management Agency (Ondraf-Niras) to establish a framework program for collaboration on issues related to the management of high-level radioactive waste in Belgium. The framework agreement started in 2021 and will run for the next five years.

During 2020 we reached an agreement with the Belgian Waste Management Agency (Ondraf-Niras) to establish a framework program for collaboration on issues related to the management of high-level radioactive waste in Belgium. The framework agreement started in 2021 and will run for the next five years.

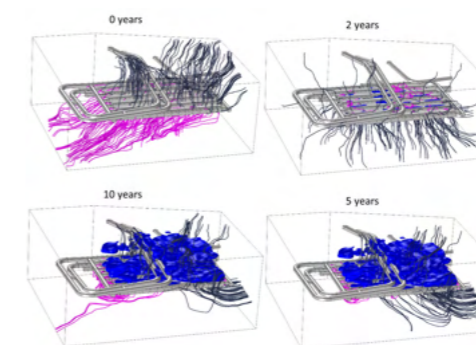

We have a well consolidated framework collaboration agreement with Andra, the French Radioactive Waste Management Agency, one of our key clients. This year the activities have included both experimental studies and numerical simulations. The projects have addressed problems related to the migration of radionuclides, saline media, chemical stability at high temperatures, and hydro-chemo-mechanical couplings of the interaction between various materials in the CIGEO repository. The latter constitute a significant advance in the integration of basic science in engineering and repository design and have been presented to the French National Evaluation Commission. The studies carried out have focused on the repository for high and medium level waste (CIGEO) as well as the repository for very low-level waste (CIRES). The results of these studies will contribute to the design of long-term safety strategies in these facilities.

Also noteworthy are our consulting services for the safety assessment of the

high-level waste programme of NWMO, the Canadian Waste Management Agency, focused on solubility studies of radionuclides under repository conditions in different scenarios of interest.

As every year, Amphos 21 maintains an active commitment to the training of human resources and R&D&I actions. We highlight the participation of Amphos 21 in the European project PREDIS (Predisposal Management of Radioactive Waste), which began in 2020. Several doctoral theses and / or masters supervised by experts from our team have also been initiated, who join those on-going theses from previous years. These efforts to keep innovation at the core of our activities have resulted in the publication of several articles in indexed scientific journals.

In connection with the development of new products, Amphos 21 continues to develop and maintain software for the implementation of advanced numerical models. In 2020, we highlight the start of several pioneering projects in the nuclear sector where the potential of artificial intelligence is being exploited for the interpretation of large volumes of data within the field of nuclear waste management and to optimize and make costly numerical simulations of coupled physical-chemical processes more flexible.

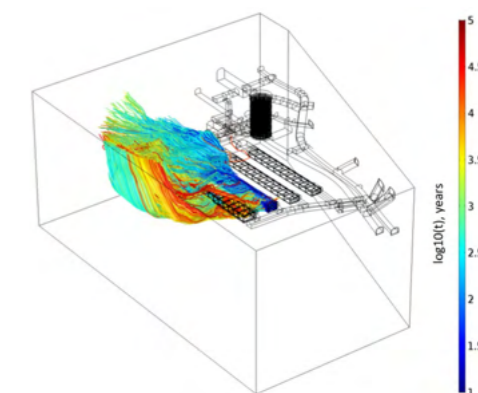

C/ Magallanes, 3
28015 Madrid
Tel.: +34 91 309 80 00
E-mail: empresarios@empre.es



Empresarios Agrupados (EA) is a leading international engineering and construction management company with headquarters in Madrid (Spain). Founded in 1971, EA has a permanent multidisciplinary staff of over 1000 persons, 80% of whom are university graduates.

EA provides a full range of engineering services for nuclear, conventional, renewables and biomass power plant projects.

In the Nuclear field, EA main areas of activity are:

- New build nuclear power plant projects.
- Engineering support services to nuclear plants in operation.
- Decommissioning and radioactive waste management projects
- Research reactors, SMRs and GEN IV projects
- Fusion technology: ITER, IFMIF-DONES, DEMO



EA has carried out the engineering for electric power generating plants projects with a combined installed power of more than 52,000 MWe, in Spain and in over 50 other countries.

EA is ranked among the "Top 225 International Design Firms" by "Engineering News Record" magazine (ENR).

EA is an independent consultant and engineering company, with quality services recognised by the market. EA's clients include electric utilities, IPPs, government agencies, reactor vendors, EPC contractors, main equipment suppliers and international organisations such as IAEA, EBRD, European Commission, ITER, Fusion for Energy, etc.

EA holds the ISO 9001:2015, ISO 14001:2015 and ISO 45001:2018 certificates.

SERVICES, PRODUCTS AND TECHNOLOGY AVAILABLE

Services and products provided by EA include: consulting, project management, engineering and design, licensing and permitting, procurement services, construction management, commissioning management, engineering support to plants in operation and quality management.

OUTSTANDING ACTIVITIES-NATIONAL

EA has been the sole or main engineering company for six (6) 1100 MWe nuclear units in Spain, (PWRs and BWRs), being responsible for a full range of project management, engineering and design, procurement, construction, plant testing and commissioning management services.

EA also provides a complete range of engineering support services to all seven nuclear units in operation in Spain. EA is also involved in modernization, design modifications due to new licensing requirements, power uprating, life extension and post-Fukushima backfitting programs for these plants.



Some EA's projects in the nuclear field in Spain are:

- Implementation of post-Fukushima project modifications at Almaraz 1&2 and Trillo NPPs and also for other domestic and foreign NPPs
- Engineering and design of the Centralized Interim Storage Facility ("Almacén Temporal Centralizado", ATC) for the spent fuel produced at all the nuclear units operated in Spain
- Engineering services for the decommissioning of José Cabrera NPP (PWR, Westinghouse, 165 MWe)
- Power Uprating Engineering services for Almaraz 1&2 NPP (PWR, Westinghouse, 2 x 1049 MWe), including new equipment implantation and control system modification



- Engineering services for the temporary spent fuel storage facilities (ATI) at plant site for the Trillo, Ascó 1&2, Almaraz 1&2 and Cofrentes NPPs
- Probabilistic Safety Analysis (PSA) for majority of the Spanish nuclear power plants.
- Engineering support services to the operation and refueling outage services for Almaraz 1&2, Trillo and Cofrentes NPPs
- Studies for license renewal and life extension for Almaraz 1&2, Trillo and Cofrentes NPPs

OUTSTANDING ACTIVITIES- INTERNATIONAL

Engineering and Consulting and Owner's Engineering Services for New Build Nuclear Power Plant projects

- Over the years EA has taken part in a number of international projects aimed at developing, licensing and implementing Generation III and III+ advanced NPPs. This includes an active participation in projects using different technologies such as Westinghouse PWRs (SPWR, AP-600, EPP and AP 1000), GE- Hitachi BWRs (ABWR, SBWR and ESBWR), Framatome PWRs (EPR), Rosatom VVERs (VVER 440, VVER- 1000, VVER 1200), Mitsubishi PWRs (APWR), etc.
- EA has been providing consulting and Owner Engineer services for plant preconstruction activities, preparation of feasibility studies, preparation of Bid Invitation Specifications (BIS) and evaluation of Bids for the new build NPPs in the majority of new build projects in Europe: e.g., Hanhikivi NPP project, in Finland, Temelin Units 3 & 4 NPP, in the Czech Republic, Next NPP at the Beznau site in Switzerland, Olkiluoto 3 NPP and Olkiluoto 4 NPP, in Finland, Dukovany NPP site in the Czech Republic, New NPP project in Jaslovské Bohunice Site in Slovakia and Akkuyu 1, 2, 3 & 4 NPP in Turkey, etc.

Staff
University graduates

Over 1,000 employees
80%

- EA has participated in the preparation of the European Utility Requirements (EUR) document for New Build NPPs of evolutionary and passive designs in Europe
- EA has also been delivering engineering and design services for the Lungmen NPP Nuclear Island project (ABWR, GEH 2 x 1360 MWe), in Taiwan, as subcontractor of GE-Hitachi.
- Also as a subcontractor of GE-Hitachi, EA has provided engineering services for the design development and Design Certification by the US NRC of the ESBWR



- For the Mochovce Units 3 & 4 NPP (VVER, 2 x 440 MWe), in Slovakia, EA has carried out the high energy pipe break analysis and protection design against the consequences of pipe break in the Nuclear Island
- Turbine Island design for Wylfa Newydd 1&2 NPP (ABWR, Hitachi-GE, 2x1360 MWe), UK
- Turbine Island general arrangement design, piping and support design for Paks 5&6 NPP (VVER 2x1200 MWe) in Hungary and El-Dabaa 1&2 NPP (VVER 2x1200 MWe) in Egypt
- Hanhikivi 1 NPP (VVER 1200), Finland. Preliminary Safety Analysis Report (PSAR) Preparation



Engineering Support to Plants in Operation:

- Design modification of the complete Class 1E Emergency Electrical Supply System for Krško NPP, (PWR, Westinghouse, 730 MWe), in Slovenia (post- Fukushima requirement)
- Establishment of a system for monitoring technical conditions of VVER NPP buildings and structures based on advanced methods and techniques in Ukraine
- Over the last 25 years, EA has been providing engineering and consultancy services for the implementation of plant upgrades and safety improvement of

Russian design VVER-440 and VVER-1000 plants in Russia, Ukraine, Bulgaria, Czech Republic, Slovakia and Armenia

Decommissioning and Waste Management Projects

- Project management services for the decommissioning of Kozloduy Units 1 to 4 NPP (VVER 440) and for the construction of the National Disposal Facility for Low and Intermediate Radioactive Waste in Bulgaria
- Project management services for the decommissioning of the VVER 440 Bohunice 1&2 NPP in Slovakia
- Radioactive Waste Management Project at the Vektor Industrial Complex in Chernobyl (Ukraine)
- Engineering support services for Decommissioning and Waste Management Program at the EU Joint Research Centre (JRC) at Ispra, Italy

Research Reactors, SMRs and GEN IV Projects

- EA has participated in more than twenty (20) EURATOM projects, funded by the EU Framework Programmes for the development of advanced nuclear reactor technologies (GEN IV), including liquid metal cooled fast and thermal breeding reactors
- JHR (Jules Horowitz Reactor), France, experimental reactor, for materials research: design of the primary circuit heat exchangers
- PBMR (Pebble Bed Modular Reactor) high temperature gas reactor project in South Africa: complete structural-mechanical engineering and design of the primary system pressure boundary and components
- Conceptual engineering for MYRRHA liquid metal reactor, Belgium
- Conceptual engineering for MINERVA Accelerator, Belgium



Nuclear Fusion Technology Projects:

- Over 20 years involvement in Fusion Technology projects development (ITER, IFMIF-DONES, DEMO)
- Architect-Engineer and Construction Management for all buildings and site infrastructure, electricity supply system, auxiliary systems and construction supervision of ITER Fusion Project, as part of ENGAGE Consortium
- Design, Manufacturing, Qualification and Installation of the Nuclear Safety Control (SCS-N) System for ITER
- Final Design of the Connection Pipes for the Test Blanket System (TBS) for ITER
- Thermo-Hydraulic Analyses for Process, and System Engineering of the Tokamak Cooling Water System (TCWS) for ITER
- Assembly and installation activities inside of the Tokamak Complex: TCC2 assembly contract, ITER
- Engineering and manufacturing of ITER First Wall Panels



COUNTRIES IN WHICH THERE IS NUCLEAR ACTIVITY

EA has carried out nuclear projects in: Spain, France, United Kingdom, Belgium, Finland, Italy, Switzerland, Slovenia, Rumania, Sweden, Norway, Russia, Bulgaria, Czech Republic, Slovakia, Hungary, Ukraine, Poland, Lithuania, Armenia, United States, Canada, Mexico, Argentina, Brazil, Bolivia, Turkey, Jordan, Taiwan, KSA, UAE, China, Japan, Egypt and South Africa

Polígono Industrial Heras, nave 136
39792 Heras, Cantabria
Tel.: + 34 942 253 815
E-mail: comercial@enwesa.com

Polig. Industrial Les Tapies
C/ Gimbernat, 15
43890 Hospitalet del Infant, Tarragona
Tel.: + 34 977 172 702



ENWESA is a well-established company in the nuclear industry, involved in many of the maintenance tasks during power plant outages and also throughout the operation cycle.

Other business areas are focused in providing specialized services for maintenance and construction of industrial facilities.

A deep knowledge of the energy business and the potential to adapt to increasingly demanding circumstances, are the key to achieve competitive project execution.



Founded in	1997
Turnover	30 million €
Payroll	250

In the BWR nuclear plants like Cofrentes, ENWESA routinely performs mechanical maintenance of valves, motors and pumps.

ENWESA also plays an active role in the spent fuel casks loading and handling in Spanish NPPs.

ENWESA's facilities are suitable for Nuclear components manufacturing, such as heat exchangers, tanks and spent fuel casks.

This activity is often part of a bigger project that include on-site installation along with component supply.

Other ongoing activities are:

- Maintenance of CCGTs
- Manufacturing and assembly projects for the shipbuilding industry (vessels and submarines)
- Robotics and process automation, specially in the automotive industry, providing turnkey projects that include engineering.

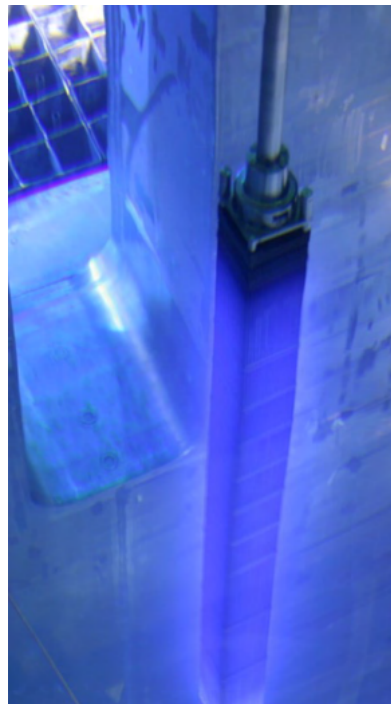
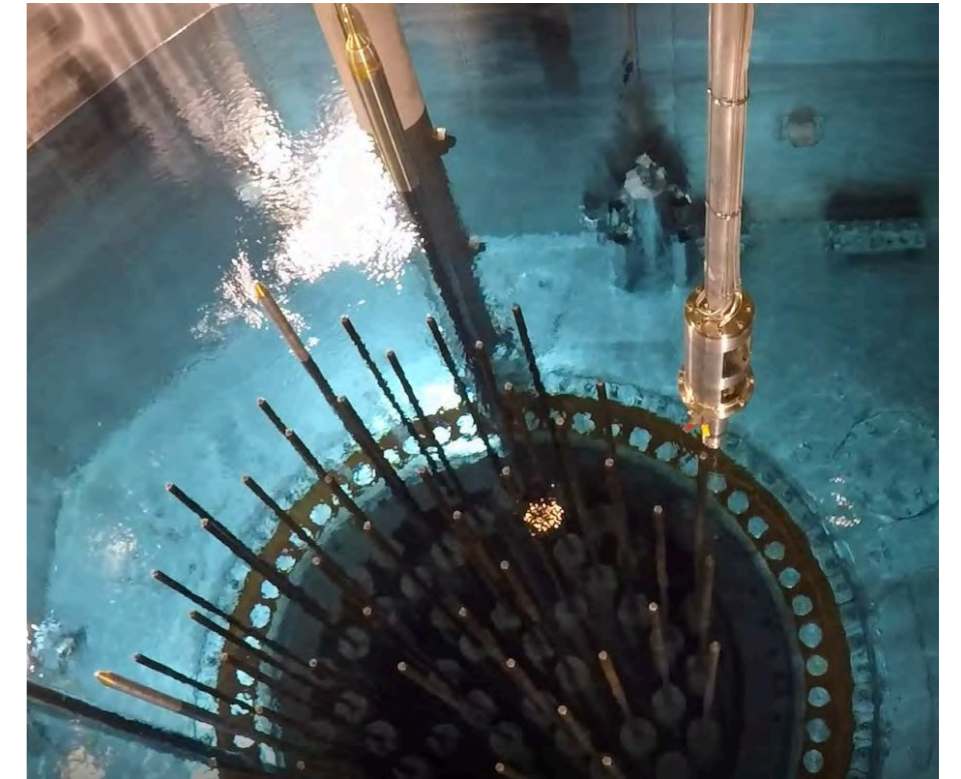

SERVICES, PRODUCTS AND TECHNOLOGY AVAILABLE

The company is organized in five areas that collaborate closely, enabling the integration of different expertise and perspectives to face complex projects:

These areas are:

- Nuclear services of NSSS components such as reactor, fuel, steam generators and reactor coolant pumps. It also includes decommissioning of nuclear facilities.
- Valves and actuators maintenance, mainly nuclear related.
- Mechanical maintenance of turbines, pumps, motors, heat exchangers and other mechanical equipment.
- Robotics and automation & control.
- Manufacturing of mechanical components, mainly for the nuclear and shipbuilding industries.

ENWESA is certified to ISO standards in Quality (ISO 9001) Environmental Management (ISO 14001) Welding (ISO 3834) Health and Safety (ISO 45001 and OHSAS 18001).

Several other certifications cover specific areas of the company.

OUTSTANDING ACTIVITIES - NATIONAL

ENWESA has an ongoing activity in all Spanish nuclear power plants that includes:

- Mechanical maintenance (during plant cycle).
- Refueling outages NSSS components maintenance.
- Fuel handling, inspection and repair.
- Valves maintenance.

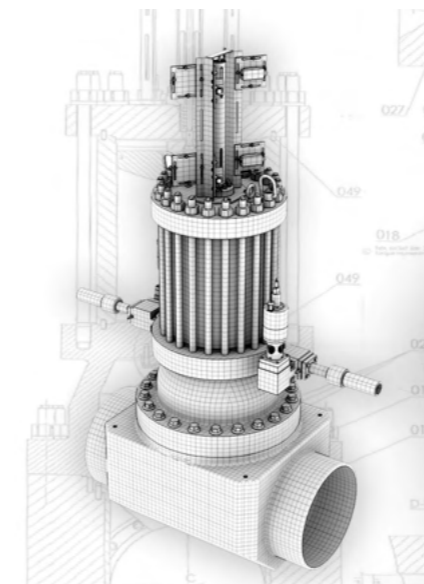

OUTSTANDING ACTIVITIES - INTERNATIONAL

ENWESA's goal is a steady growth in several countries. However, the special circumstances of year 2020 have reduced the company's international presence to some extent.

The main international activity is valve maintenance in France, where ENWESA is well established and holds a continuous workload all year round, with recent projects in Bugey, Golfech and Chinon.

COUNTRIES IN WHICH THERE IS NUCLEAR ACTIVITY

The main international business area for ENWESA is France, where it has been growing throughout the last decade and currently has permanent resources.

Nowadays ENWESA is well known as a valve maintenance supplier in many of EDF's power plants.

ENWESA has been working in nuclear power plants in Belgium, Finland, Brazil, Mexico and Slovenia.

Headquarters
Ronda Auguste y Louis Lumière 15.
Parque Tecnológico de Valencia.
46980 Paterna (Valencia), Spain
Tel: +34 963540300

Madrid Delegation
C/ Aduana, 33, 3º
28013 Madrid
Tel.: +34 916 409 870
E-mail: info.es@gdes.com



GD Energy Services (GDES) is a Spanish based business group with over 85 years of experience providing industrial services for a wide range of customer profile **O&M support, surface treatments, radiation protection, decommissioning, services for the wind power industry, logistics and emergency response.**

Since 2020, GDES has incorporated **Digital Transformation and Business 4.0** into its activity, accompanying companies in the digitisation of the industry for more agile and intelligent decision-making, turning data into profitability. Our broad diversification makes our group one of the most predominant and visible in the energy sector, giving the company a strong market presence. GDES currently employs a staff of over 1,500 professionals actively working in 10 countries. An eminently qualified team, fully oriented toward our customers, providing high added-value solutions adapted to the specific requirements of each project.

BUSINESS OBJECTIVE

In recent years, the new challenges of an increasingly globalized industry and the high-growth strategy of the company have acted to greatly increase its international presence in global markets, with overseas business making up an increasingly important part of GDES' business activity and revenue. Currently, the Group is active in Spain, France,

the United Kingdom, Portugal, Italy, Sweden, Mexico, Panama, Brazil, and the United States, with projects in these and other potential markets gaining in importance.

MAIN BUSINESS UNITS FOR THE GROUP

NUCLEAR SERVICES, SURFACE TREATMENT, DECOMMISSIONING, WIND, DIGITAL TRANSFORMATION AND BUSINESS 4.0, LOGISTICS, EMERGENCY RESPONSE

NUCLEAR SERVICES

• O&M support

- Mechanical and chemical decontamination
- Waste management
- Fuel movement support
- Support for refueling services
- Radiological emergencies
- Decontamination
- Hydrostatic testing
- Sludge treatment
- Biological disinfection solutions

• Thermal protection

- Passive fire protection
- Penetration seals (electrical and mechanical)
- Thermal insulation that is both Reflective (with an option for radiation shielding) as well as Conventional
- Signage and identification of systems
- Design, calculation and assembly of scaffolding and permanent access ways
- BIM modelling. Digital twin.

• Radiological protection

- Radiological Protection Services
- Radioactive waste management radiological characterisation of installations - Official and on-demand dosimetry readings - Official and ad hoc courses for radiation facilities according to the customer type
- Support for refuelling services
- Radiation facilities supervision
- Detection of radioactive and nuclear material. - Orphan sources
- Legalisation of facilities
- Radiological and Encapsulated Source Hermetic Sealing Verifications
- Radiological Emergency Services
- Biological decontamination consulting

• Long term operation

- Structural analysis of systems and components - Root-cause evaluation of failures
- Thermohydraulic and functional validation
- Critical components residual lifespan evaluation, assessment and management
- Commercial components third-party dedication to nuclear / harsh environment
- Reverse engineering of legacy components no longer supported by their OEMs

SURFACES TREATMENTS

- Surface preparation: - Abrasive blasting - Shot blasting, and - High-pressure water
- Surface Treatment by Sponge-Jet
- Corrosion protection: - Maintenance - Primers, paints and coatings
- Concrete treatments: - Repairs - Structural reinforcements
- Passive fire protection
- Application of pavements
- Metallisation (arc spray)

DECOMMISSIONING

- Dismantling of radioactive and nuclear facilities: - Power Plants - Experimental reactors - Equipment and components (Globe box, hot cells, etc) - Radioactive installations

Revenues (FY 2020 aggregated)
Workforce

104 million €
1,500 employees

- Technical Support
- Feasibility Studies
- Radiological Protection
- Waste Characterisation
- Decontamination services

WIND

- Maintenance (preventive and corrective) in factory and field
- Retrofitting
- Technical assessment
- Periodic inspection (thermography and ultrasound)
- Technical consultancy
- Rotor balancing and vibration dampening
- Long-term operation
- Logistics solutions for blades, parts, and materials
- Cutting, scrapping and management of end-of-life blades
- Manufacturing of composite parts

DIGITAL TRANSFORMATION AND BUSINESS 4.0

- Digital maturity assessment
- Definition of the digital transformation roadmap
- Development of profit-oriented digital solutions
- Detection and definition of business problems and goals
- Real-time data management and integration
- Process optimization through predictive algorithms
- User experience design
- Industrialization in the business environment
- Ad-hoc projects for various sectors: - Energy sector - Health sector - Food industry - Automotive - Manufacturing

LOGISTICS

- **Warehouse management:** - Reception and forwarding - Loading docks - Picking, labeling, handling - Internal transport

• Integrated "in-house" logistic management:

- Handling of internal flows
- Circular economy
- Provisioning
- Internal distribution
- Manual finishing and packaging
- Packing
- Equipment optimization

EMERGENCY RESPONSE

- Professional fire brigades
- Training of fire and emergency personnel
- Maintenance of fire suppression systems
- Consulting
- Emergency response plans and self-protection manuals
- Patient transportation (urgent or scheduled)

PAST WORK AND REFERENCES

DECONTAMINATION, CLEANING AND MAINTENANCE SERVICES IN:

- Spain: Almaraz NPP, Asco NPP, Cofrentes NPP, Santa Maria de Garoña NPP (recharge), Trillo NPP, Vandellós II NPP, Vandellós I NPP, El Cabril, CIEMAT
- France: Fessenheim NPP, Bugey NPP, Civaux NPP, Golfech NPP, Chooz NPP, Chinon NPP, Blayais NPP, Iter, St Laurent NPP, Nogent NPP, Tricastin NPP, Belleville NPP, Gravelines NPP, Cruas NPP.
- Mexico: Laguna Verde NPP.

DECOMMISSIONING

- Andujar Uranium Factory (FUA)
- Ciemat facilities (PIMIC)
- Vandellós I Nuclear Power Plant
- Arbi Experimental Reactor
- Jose Cabrera Nuclear Power Plant
- Galileo Galilei Reactor, CISAM (Pisa, Italy)
- Dounreay, Winfrith and Springfields NPPs (UK)
- CEA Marcoule (France)
- JRC -Ispra (Italy)



Support for Radiological Protection at the JRC in Ispra (Italy), hospital and industrial facilities (Spain)

Chemical Cleaning Secondary side of Steam Generators for EDF in Dampierre 1 & 2 NPPs (France).

Treatment of effluents from chemical cleaning of Dampierre 1 (France).

Application of special coating (EXTRADOS) in Cattenom 3 and Flamanville 1 & 2 NPPs, Blayais NPP and ITER (France).

Cross Under Metallization for the Laguna Verde NPP (Mexico).

Metallization of GSS water boxes: Civaux NPP, Belleville NPP, Bugey NPP and Nogent NPP (France).

Passive fire protection in Vandellós II NPP, Almaraz NPP and Cofrentes NPP (Spain).



C/ Los Llanos de Jerez, 10-12
28823 Coslada, Madrid
Nuclear Area
Tel.: +34 916 603 066
E-mail: enavarron@geocisa.com



GEOCISA is a highly skilled company with expertise across a range of technical projects: Geology and Geotechnics, Instrumentation and Monitoring, Soil Investigation and Ground Treatments, Deep Foundations, Laboratories, Infrastructure Management and Highway Maintenance, Restoration and Rehabilitation of Monuments, Bridges and Singular Buildings and Environmental Protection. GEOCISA is a sister Company of DRAGADOS, an international contractor established in 1941 that specializes in major infrastructure projects worldwide. DRAGADOS is the construction arm of ACS Group, which is one of the leading infrastructure developers in the world with a presence in more than 40 countries.

In the nuclear field and involved in the conservation and protection of our environment, GEOCISA founded over 35 years ago Environmental Testing Laboratory as a demonstration of environmental commitment, performing both chemical and radiochemical measurements in different matrices.

The experience gained over the years attached to both human and technological multidisciplinary team makes GEOCISA part, from the beginning, in the first decommissioning of a Spanish nuclear power plant, Vandellós I.

Characterized by the constant pursuit of innovation and effort in research and development it means that, with the arrival of new phases in the life cycles of facilities, new challenges are taken: new matrices and test new isotopes not previously determined.

Our participation in Preoperational and Operational Programs for Nuclear Power Plants, Operational Program of the Center

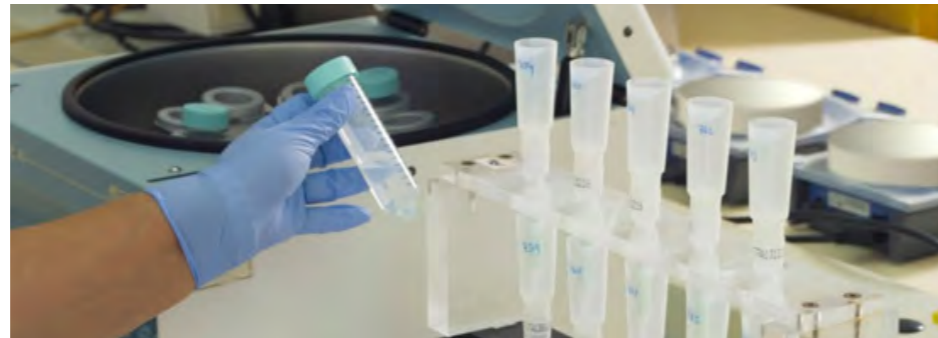

for Disposal of Radioactive Waste Cabril Surveillance Program Uranium mining, positions us as a specialized laboratory with extensive knowledge both artificial and natural radioactivity radioactivity , amply able to tackle any type of monitoring program in all types of sites.

Quality is a constant reference in the pursuit of our activities so GEOCISA has an accredited system according to ISO-9001 , ISO-14001 and OHSAS-18001 standards, and is also approved Evaluation Group Suppliers of the Spanish nuclear power plants .

SERVICES, PRODUCTS AND TECHNOLOGY AVAILABLE

Environmental Radiation Monitoring Programmes

Since its creation in 1978, the laboratory GEOCISA is positioned as a reference for the realization of Environmental Radiation Monitoring Programmes in the Spanish nuclear power plants. Experience allows us to manage all phases of the programs:

- Program Design , implementation of the land census
- Run field : in situ measurements, sampling , storage and transportation to the laboratory

- Implementation in the laboratory sample receipt and acceptance, processing, analysis and radiation measurement.
- Data and report management, analysis of results

Technical support personnel to nuclear facilities

This is the case GEOCISA participation, since 1992, in Central Radioactive Waste Storage Medium and Low Activity El Cabril (Córdoba), where we have developed new methods and procedures for the set-up of Quality Verification of packages Laboratory .

RPTU Scope: Decommissioning nuclear facilities

Although the beginnings of the Radiological Protection Technical Units were in the hospital setting, GEOCISA broadens the scope to nuclear area adapting to the activities in which the laboratory has been involving in the field of decommissioning projects of nuclear facilities.

The other two main priorities of the RPTU are:

- Monitoring programs impacted sites: composed of measures in depth (radiological borehole) with radiation measuring equipment prototype developed by GEOCISA and radiochemical sampling for laboratory analysis.

Founded in	1968
Turnover (annual)	3 million €
Total workforce (Nuclear Area)	31 employees
% of university graduates	22%

- Projects Liberation of places: composed of measures in land surface by applying MARSSIM methodology, measuring equipment prototype developed by GEOCISA radiological and radiochemical samples for laboratory analysis.

Bioanalysis : Dosimetry by bioelimination

In 2007 the process of tuning up Bioanalysis Laboratory, specializing in measurement of body radioactivity in urine and feces lab starts.

In 2010 the Nuclear Safety Council issued the authorization of Internal Personal Dosimetry Service Tecnatom , being GEOCISA laboratory responsible for carrying out the measures of body radioactivity bioelimination.

The determinations made in this laboratory are:

- Determination of americium, uranium isotope, curium and plutonium in urine samples.
- Determination of strontium and tritium in urine samples.
- Determination of creatinine in urine samples.
- Determination of americium isotopes of uranium, plutonium in faecal samples.

NORM Studies

Since the publication of Royal Decree 1439/2010, the Regulation on Health Protection against Ionizing Radiation and the 11.2 Safety Guide on "Control of exposure to natural sources of radiation" of Nuclear Safety Council which recommended that these studies are conducted by the Radiological Protection Technical Units or laboratories with expertise in radiation protection as natural radioactivity , the Radiochemistry laboratory and RPTU of GEOCISA and incorporating such studies in its activities.

OUTSTANDING ACTIVITIES- NATIONAL

- Environmental Radiation Monitoring Programmes (NPP José Cabrera, Asco, Vandellos I and II and El Cabril)
- Water control program in the vicinity of the Andújar Uranium Mill (FUA)
- Operator spectrometry ISOCS kind for ENRESA
- Internal Personal Dosimetry Service by bioelimination for the dismantling of the NPP Jose Cabrera
- Radiological Protection Service for the proposed decommissioning and dismantling of the NPP Jose Cabrera
- Radiological analysis of samples related to the CRI-9
- Technical Service laboratory instrumentation and radiological measures PIMIC-CIEMAT project
- Exploitation of the laboratory of Central Radioactive Waste Storage Medium and Low Activity El Cabril
- Release of land in the NPP Vandellos I
- Characterization of land and buildings screeds NPP Jose Cabrera

- Monitoring of groundwater and contaminated land area SROA
- Emergency Analysis Laboratory and radiological analysis of samples RPTU
- Quality Control Process declassification of materials and surfaces characterization and decontamination workshop on NPP Jose Cabrera
- Quality Control Process declassification of materials Montecillo (PIMIC Phase III)
- Turbine Island radiological characterization of NPP Sta. Mª Garoña as part of the temporary consortium UTE CHARACTERIZACION 4 SMG 1.

OUTSTANDING ACTIVITIES- INTERNATIONAL

- Project technical advice and training of NPP Kozloduy (Bulgaria) for physico-chemical solid and liquid samples within the Project Decommissioning of the facility characterization.





GRUPO EULEN was founded in 1962, becoming a pioneer in the industry by offering the market a professional cleaning service for the very first time. The company's extensive experience and the training undertaken by its professionals means Grupo EULEN now specializes in a range of sectors, including nuclear, automotive, steel, industry, petrochemicals, pharmaceuticals, department stores, hospitals, agriculture and food, transportation and office buildings.



With its range of specialist companies, Grupo EULEN offers the following services to the Nuclear sector:

- Specialist technical cleaning
- Decontamination
- Security (EULEN SEGURIDAD)
- Radiation protection (PROINSA)
- Declassification of material
- Radioactive waste management
- Maintenance
- Environment and Gardening
- Radiation and environmental measures (ENVIRONMENTAL MEASURES)
- Conventional cleaning

The company has certificates that guarantee the quality of the services we undertake:

- ISO 9001:2008 quality standard
- UNE 73401:1995 quality standard
- ISO 14001:2004 environmental management standard
- OSHAS 18001:2007 risk prevention

SERVICES, PRODUCTS AND TECHNOLOGY AVAILABLE

Grupo EULEN has extensive presence and experience in providing all kinds of services to nuclear power stations and radioactive facilities:

- Technical cleaning and radioactive decontamination services
- Cleaning and decontamination of buildings, facilities and equipment in controlled areas
- Cleaning and decontamination of parts, tools, equipment, etc.
- Cleaning of vessel studs and nuts for the Rx and SGs

- Decontamination of material and scrap metal
- Classification and management of contaminated material
- Waste conditioning and containment
- Support (staff and equipment) during refueling and outages
- Installation and conditioning of SAS
- Filtration of refueling cavity water
- Establishing and logistics of transit points
- Hydrodynamic cleaning with pressure washing
- Cryogenic cleaning with CO₂
- Cleaning of heat exchangers, condensers, water boxes, pumps, tanks, intakes and supplies, pools, cooling towers, etc.
- Scaffolding, logistics and industrial support
- Decontamination interventions in incidents with radioactive sources (recovery units, steel plants)
- Fire fighting services



Turnover (2019)	1,585.94 million €
% International sales	23%
Global staff	81.739 employees
Staff in Spain	48.715 employees
Countries in which the company operates	14



EQUIPMENT

The company has access to the following wide range of equipment for services provided in the nuclear sector:

- Combined extraction and induction equipment
- Vacuum trucks
- High pressure hydrodynamic equipment (2000kg/cm²)
- Specific equipment for cleaning air pipes
- Cryogenic cleaning equipment
- Specific equipment for cleaning vessel studs and bearings, SG studs
- Etc.



ACTIVITIES AND REFERENCES

Grupo EULEN has been involved in the nuclear industry for more than 35 years, working for the following Nuclear Power Plants:

- Santa María de Garoña
- Ascó I & II
- Vandellós
- Almaraz
- Trillo
- José Cabrera
- Cofrentes

At some of these facilities, Grupo EULEN has worked on the construction stage, as well as on operations and refueling.



Grupo EULEN has also undertaken activities relating to the nuclear sector at the following facilities:

- El Cabril low and intermediate nuclear waste repository (Enresa)
- Enusa
- Radioactive decontamination work in the Scrap Metal Recovery sector and at Steel Plants, in collaboration with PROINSA (radioactivity monitoring).



IDOM CONSULTING, ENGINEERING, ARCHITECTURE, S.A.U.

Headquarters
Avda. Zarandoa, 23
48015 Bilbao (Vizcaya)
Tel.: +34 944 797 600
E-mail: nuclear@idom.com

Avda. de la Fama, 11-15. Edificio Arce
08940 Cornellá de Llobregat (Barcelona)
Tel.: +34 934 092 222

Avda. Monasterio de El Escorial, 4
28049 Madrid
Tel.: +34 914 441 150

No.1 St Ann Street
Manchester M2 7LR. Manchester. UK
Tel.: +44 161 302 0950



The professional services offered by IDOM Consulting, Engineering, Architecture, S.A.U. (IDOM) cover most of the industrial and technological activities carried out in a nuclear installation, both in the fields of fission and fusion and nuclear fuel cycle. The organizational structure of the company allows us to offer a wide range of technical solutions, assistance and management services.

IDOM distinguishes itself as a company that has the capacity to integrate the expertise and experience of the nuclear division and draw on the support of all the professionals of the Group, responding efficiently and effectively to the requirements of each project and the needs of each client.

The integrated approach of IDOM involves multidisciplinary teams with expertise from the different technical areas of the Group: Consulting and Systems, Industry and Energy, Architecture and Building, Infrastructure and Nuclear Services. All these disciplines are coordinated using project management practices that guarantee the correct technical and economic outcomes of the projects.

Specifically in the field of Nuclear Services (NS), IDOM is an approved supplier of the quality assurance group of Spanish NPP's, ENRESA, UNESA, FRAMATOME, NA-SA, Rolls Royce and F4E (ITER), and possesses certifications from ROSATOM's contractors (TITAN2). In addition, IDOM has in place, a nuclear quality assurance system audited according to the standards NQA-1, ISO-9001, UNE- 73401 and KTA 1401. Moreover, IDOM has successfully implemented the OHSAS 18001 Certification requirements (Health and Safety on working sites) as well as the Environmental Management System of UNE-EN-ISO 14001

SERVICES, PRODUCTS AND TECHNOLOGY AVAILABLE

PROJECT SERVICES

Integral Solutions from conceptual design to full integration into operation of nuclear facilities, both power and research. Those services can be provided individually or as an integrated package assuming the full responsibility, as per the specific client needs, covering all areas of engineering, project management, procurement and logistics, construction management, commissioning and start-up support, operational support and decommissioning. IDOM can participate as:

- EPCM
- Project Management (PMC)
- Owners' Engineering
- Technical Assistance
- Design & Engineering (D&E)
- Advanced Analyses Studies
- Nuclear Consulting

And for some specific projects, assuming EPCM / EPC contracts.

NUCLEAR CONSULTANCY

IDOM independence, together with more than 40 years of nuclear expertise, provides us a global vision to support our clients on strategic, financial and technical nuclear industry challenges:

- Nuclear Strategic Consulting (Nuclear Programs, National Plans, Business Plans)
- Engineering of Safety-Cost-Benefit Solutions (Optioneering)
- Engineering of Digital Technologies and Industry 4.0 (Configuration Management, ILCM)
- Support to the client in front of the regulator
- Safety and Licensing
- Asset management

DESIGN & ENGINEERING

Taking into consideration the unique requirements of each project, applicable regulations and the requirements of the Nuclear Regulator of each country, IDOM performs engineering in the fields of

- Systems Conceptual, Basic and Detailed Design Engineering.
- Specifications and Design Modification
- Components, Structures and Systems (SSCs) Analysis and Seismic Qualification
- Radiological Protection and Shielding.
- Back-end engineering (spent fuel storage, radioactive waste management, decommissioning).
- Support Engineering and Maintenance (Plant Engineering).

IDOM carries out all the above activities in National and International Projects and in different nuclear technology applications such as power generation, health, environment, industry, defense or research.

In addition to the traditional Engineering services, IDOM NS has developed a multitude of special products related to safety and licensing:

- Lifetime Management.
- IPEEE and Stress Test.
- Fire Protection and Explosions.
- Ionizing Radiation Technology.
- Safety and Licensing.

ADVANCED ANALYSIS STUDIES

To develop the special analyses that are required for NPPs or nuclear fusion plants, IDOM offers the following activities:

- Fire simulations with FDS.
- Ionizing radiation calculations
- Design Analysis of Nuclear Class SSCs and non-linear calculations.
- Gas Performance, mechanical and fluid dynamics simulations, CFD calculations.

Founded in	1957
Turnover [2020]	290 million €
International Activity	90%
Projects developed in over 125 countries	45 offices
Staff	3,800 employees
Superior degree holder employees	90%

- Thermo-hydraulic Analyses (MAAP, RELAP, MELCOR, GOThIC).
- Advance mechanical calculations
- Software development (manipulation of radiation maps, scripts for the mapping of neutronic deposition, code coupling, mesh manipulation scripts).

OUTSTANDING ACTIVITIES - NATIONAL

- Lifetime Management in Spanish NPPs.
- Individual Spent Fuel Storage Installation (ISFSI) at Santa M^a de Garoña NPP.
- Engineering services for Garoña NPP Decommissioning.
- Technical Assistance in Periodical Safety Review. ANAV.
- Plant View. ANAV.
- Consulting Services for Business positioning. Spain.
- Detailed Engineering for the upgrade of the HVAC and Fire Protection (extinction, detection and dampers) in several NPPs.
- Stress Tests and Design Modifications for safety enhancement in numerous NPPs (Post Fukushima Requirements), based on detected vulnerabilities as a result of the Seismic analyses, flooding, and other external events (Alternative Emergency Management Centre, Heliport, Improvement of Drainage Systems and implementation of Large Flow Drainage Systems, Structural Reinforcement as well as improvement of equipment and systems, Containment Filtered Venting System (CFVS)).
- Cask Maintenance Workshop (TMC) for the CSFSF of ENRESA.
- EJ System: Substitution of Ultimate Heat Sink at Vandellós II NPP. "Turnkey Project".

- Radiological Impact Study associated with the Long Term Operation of Almaraz I-II NPPs.
- Re-Racking spent fuel pool at Vandellós II NPPs.
- Support for IFMIF-DONES in safety analyses

OUTSTANDING ACTIVITIES - INTERNATIONAL

- Radiological Impact Study associated with the Long Term Operation of Almaraz I-II NPPs.
- Re-Racking spent fuel pool at Vandellós II NPPs.
- Support for IFMIF-DONES in safety analyses
- Emergency Control Room at Krsko NPP, Slovenia, in consortium with Tecnomat.
- Improvement of national personnel training system in the field of radioactive wastes, decommissioning and remediation in Ukraine for the European Commission.
- Design and Analysis of main equipment for Hinkley Point C NPP, UK.
- Commissioning support and supervision at Taishan I NPP, China.
- Engineering associated to the Individual Spent Fuel Storage Facility (ISFSI) In Atucha I NPP, Argentina.
- RAW management for operation and decommissioning of Kozloduy NPP, Bulgaria.
- Strategic evaluation of the Chilean nuclear program, Chile.
- Strategic Consultancy Services for the implementation of R&D nuclear centre, Bolivia.
- Technical expert services for the sensitivity study of seismic hazard prediction, for Finland NPPs.
- Neutronic Studies (Framework contrat) for IRSN, France.
- Moltex Engineering services for SMR development in Canada.
- Heat Exchange design for Sizewell B NPP, UK.,
- Installation and Commissioning of alternative refrigeration equipment at Krsko NPP, Slovenia
- Engineering support on piping under RCC-M code for French NPP
- Argentina
- Belgium
- Bolivia
- Brazil
- Bulgaria
- Canada
- Chile
- China
- Colombia
- Emirates
- Finland
- France
- Israel
- Lithuania
- Mexico
- Netherlands
- Slovakia
- Slovenia
- Spain
- Turkey
- UK
- Ukraine

COUNTRIES WHERE HAS NUCLEAR ACTIVITY



SERVICES, PRODUCTS AND TECHNOLOGY AVAILABLE

PROINSA is authorised by the Spanish Nuclear Safety Council as a Radiological Protection Technical Unit against ionising radiation.

This permit has allowed it over the years to become specialised in offering radiological protection and environmental services, which can be classified as follows:

Radiological protection in nuclear power plants.

- Services in normal production.
- Services in refuelling outages.
- Services during decommissioning.

Control and radiological protection of radioactive sites.

- Radiological control.
- Elaboration and processing of documentation.
- Advice and management with respect to public entities.

Training in radiological protection.

- Supervisors and operators of radioactive installations.
- Directing and operating medical and/or dental radiodiagnosis.
- Other specific radiological protection courses.

Protection services against exposure to natural radiation in NORM Industries.

Management of radioactive materials in operation and decommissioning.

Nuclear and radiological emergencies.

Environmental radiological surveillance services.

Environmental studies and projects.

Protocol and collaboration on the monitoring of metallic materials.

Firefighting squads and services.

Industrial waste management.



Turnover	7.4 million €
Volume of sales that comes from the nuclear sector	90%
Investment in R+D+i	Integrated in the Eulen Group
Staff	127 employees
Managers	4
Senior Engineers	25
Engineers	8
Technicians and administrative workers	90

All of the activities carried out are included in the Quality Management System, certified by Det Norske Veritas (D.N.V.) in accordance with ISO Standard ISO-9001:2015 and in the Environmental Management System, also certified by D.N.V. in accordance with ISO Standard ISO-14001:2015.

ACTIVITIES AND REFERENCES

Throughout its course, PROINSA has provided permanent support to the radiological protection services of the nuclear power plants of Asco I and II, Vandellós II and Santa Maria de Garoña, during their normal operation (closed radiological protection shifts, instrumentation, etc.) as well as support in radiological protection during refuelling outages in the same plants and in the nuclear power plants of Jose Cabrera, Cofrentes and Trillo.

It also provides several specific radiological protection services for other clients such as ENRESA, CIEMAT and AGENCIA TRIBUTARIA.

Since it was founded PROINSA has also provided services to both medical and non medical radioactive installations, offering the maximum scope and guidance in radiological protection. Clients include Siemens, Smurfit, Unión Española de Explosivos, etc.

PROINSA has also delivered courses related with radiological protection, including, official courses for personnel in radioactive installations, as well as other specific courses for nuclear power plants and courses on radiological protection for different official institutions.

It is a leading company in services in nuclear and radiological emergencies since it was contracted by the CSN in 1998 until 2016. It has participated actively in all of the important incidents that have occurred in the country, before and after signing the protocol of collaboration on the monitoring of metallic materials. Clients include Egmasa, Siderúrgica Sevillana, Arcelor, Nervacero, etc.

It has collaborated with all the Spanish nuclear power plants in matters relating to environmental radiological surveillance plans and with Trillo nuclear power plant as well in monitoring the ecosystems surrounding it.

Services during Vandellós I Nuclear Power Plant dismantling and PIMIC Project have been carried out.

Services against natural sources of radiation have been carried out for GAS NATURAL FENOSA.

Management of radioactive material have been carried out for NUCLENOR and ENRESA.





With more than 60 years of know-how, **Tecnatom** has made quality one of the main principles of its activity, competing with its experience and contributing with innovative solutions to the global nuclear challenge.

BUSINESS OBJECTIVE

Tecnatom was created in 1957 as a Spanish engineering company specialised in guaranteeing the operation and maintenance of nuclear power plants with the highest levels of security.

The main activities are focused on services to inspect components and structural integrity, the training of personnel in advanced training environments and support engineering to the operation of plants, relying in digitization tools which support our clients in their path toward the industry of the future, more efficient and sustainable. Today it is a business group with subsidiaries in United States, France, United Kingdom, Mexico, Brazil, Portugal, Slovenia, United Arab Emirates and China, which carries out activities in several sectors, among them energy, petrochemicals, rail transport and aerospace.

The company offers services and develops products with a high technological content and its own technology, adapted to the needs and requirements of the different clients and markets and possessing mechanical, electronic and data processing resources in the state of the art of technological development.

Tecnatom develops projects in 40 countries worldwide and its methodology and equipment have been validated by clients and regulatory authorities at an international level.

The company is also deeply involved in future developments, consolidating its participation in advanced projects for nuclear energy plants, such as the construction of new plants worldwide and the development of new reactor concepts, as the SMR.

Tecnatom participates actively in fusion reactors and research reactors such as the great international ITER project in France and the Jules Horowitz Research reactor (JHR) in France.

Tecnatom has provided advanced and sophisticated technology for the nuclear sector for almost six decades. Its role within the international nuclear projects in this period has allowed the company to adapt its technological capacities to a very demanding environment, providing innovative solutions to the global nuclear and technological challenge.

SERVICES, PRODUCTS AND TECHNOLOGY AVAILABLE

Tecnatom provides services and products with their own design and manufacture in order to continuously adapt to the needs and requisites of the different clients and markets.

A relevant part of Tecnatom's activity is devoted to the evaluation of the

structural integrity of the main components of nuclear power plants and other industrial facilities. Tecnatom has achieved huge international experience and references.

Its inspection and testing services have been approved and certified by many organisations and international clients. Its basic capacities include:

- **Inspection services:** complete capacities to perform an automated inspection using NDT of all the areas of the reactor pressure vessel, fuel assemblies, steam generators, heat exchangers and other relevant components such as piping and turbines.
- **Testing services:** a wide range of advanced tests for the evaluation of the status of the different components of the site.
- **Engineering services:** in the areas of life management, codes and standards, implementation of inspection programmes, maintenance and reliability of equipment, management of parts and components with special emphasis on the support of plant asset management and the long term operating programmes.

Using the technological development and the application of its services, Tecnatom contributes to improving the training and efficiency of the personnel of the plants, as well as implementing the best resources to facilitate the operation of the sites, thus guaranteeing improvements in safety, availability and economic efficiency

Turnover (2020)	86.3 million €
Volume of sales that comes from the nuclear sector	86%
Destinated to exports	33%
Investment in R&D	4.2 million €
Staff	785 employees
Management	18
Senior Engineers	439
Engineers	111
Technicians and admin. workers	217

guaranteeing improvements in safety, availability and economic efficiency

• **Nuclear Training:** with more than 35 years of experience in the application of the most advanced training methodologies, Tecnatom has more than 160 specialised professional instructors in the different technologies of generation II, III and IV, which makes us the leader in training services for the Spanish nuclear industry sector and provides us with an important presence in countries with nuclear projects.

• **Emergencies and Operational Support:** operating procedures and severe accident procedures assistance in the field of nuclear emergencies, specialised services to support start up, operational experience, radiological protection and dosimetry.

• **Control Rooms and Simulation:** using in-house technology, Tecnatom provides the best solutions in the areas of training and engineering assisted by simulation in the design and supply of new control rooms, as well as their modernisation.

• **Safety Management:** providing high added value services that reinforce the management of the sites and the development of additional competences in matters of safety culture and leadership.

Tecnatom has developed its own technology of automated inspection systems and, as a result, has become a provider of high level technological services and products, with the support

of the companies in the Tecnatom group to guarantee global and reliable solutions for any need.

• **NDT inspection systems:** Tecnatom designs and manufactures complete inspection systems for a wide range of applications tailored adapted to the specific requisites of the client.

• **NDT Equipment:** Tecnatom offers data acquisition and analysis systems, developing also software for a wide spectrum of non destructive test applications.

• **Design and Development of Products:** both standard and adapted to the needs of the client, including the operational procedures and the services of technological engineering.

COUNTRIES IN WHICH THERE IS NUCLEAR ACTIVITY

Argentina, Brasil, Mexico, The United States of America, United Kindom, Finland, Belgium, France, Switzerland, Slovenia, Romania, Russia, United Arab Emirates, China, Taiwan and South Korea.





VIRLAB, Expertise in Vibrations and shocks. Testing Laboratory

An Urbar Ingenieros Group Company
 Polígono Industrial Asteasu. Zona B, Nº 44
 20159 Asteasu (Guipúzcoa, España)
 Tel.: +34 943 691 500
 E-mail: laboratorio@virlab.es



Created in 1976, within URBAR Ingenieros, group of companies specialized in the industrial applications of vibration, **VIRLAB** develops its activity in the field of tests of vibration of all types of equipment, which is required continue fulfilling the purposes or are designed, in the case that they will be subjected to earthquakes or other types of vibrations.

VIRLAB has its own testing procedures, established in accordance with the requirements applicable to each case, international standards and depending on the customers' particular requirements.

VIRLAB gives a comprehensive and tailored service to the needs of its customers, without them having to worry about nothing more than to get their equipment to its facilities and collect them after testing. More than 3,150 tests have been conducted at its facilities located in Asteasu (Guipúzcoa), between San Sebastian and Tolosa and just over one hour from Bilbao airport.

FACILITIES

- A shop of 11x18m that includes a Control room, of 4.3 x 8.4m.
- A bridge crane of 10m, with two hooks 10 and 3 tons load and maximum elevation 6 m.
- A hydraulic central driven 40 CV engines 2 and 4 engines 50 CV, capable of providing up to 250 bar (210 bar, nominal pressure) and flow rate up to 640 l/min.
- An auxiliary assembly room of about 1000m² with 2 bridges crane 16 and 20 T.

- A complete set of electrical, pneumatic, hydraulic facilities and power supplies that make that equipment can be tested under real conditions of operation.
- Equipment testing and data collection and monitoring instruments as indicated below.

TEST PLATFORMS

Biaxial oil hydraulic EDB 250

- 2500x2500mm.
- 2x150kN.
- ±125mm.
- 800mm/s.
- 6g.
- 0.1 a 200Hz.

Biaxial oil hydraulic EDB 120

- 1200x1200mm.
- 2x100 kN.
- ±125 mm.
- 1,000mm/s.
- 10g.
- 0.1 to 150Hz.

Monoaxial electrodynamic, LDS 824 LS

- 750x750mm.
- 27kN.
- ±19mm.
- 1.78mm/s.
- 60g.
- 1 a 3200Hz.

Monoaxial electrodynamic, LDS 824 LS

- 2.2 kN.
- ± 12.7mm.
- 1.54mm/s.
- 100g.
- 1 to 5000Hz.

INSTRUMENTATION

VIRLAB systems data and measure elements allow us to analyze all kinds of variables: accelerations, displacements, deformations, strains, etc. Then, the instruments available to the laboratory.

Vibration Controllers

- Sine, random and shock controller: Eight input channels and one output channel (3).
- Random, shock and SRS controller: Four input channels and two output channels (1).
- Sixteen input channels and two output (1).

Sensors of vibration

- 32 piezoelectric accelerometers.
- 6 four channel amplifiers.
- 8 single channel amplifiers.
- 2 laser sensors ± 1 and ± 50 mm.

Signal monitoring

- Discontinuity Detectors, 12 channels, (0.5-20 ms), (2).
- A data acquisition and processing system, 31 channels, 200 kHz (1).
- A data acquisition and processing system, 24 channels, 1 MHz (2).

Signal analyzers

- 16 channels.
- 8 channels.
- 4 channels.

Signal recorders

- 24 input channels and 24 output channels (1).
- 24 input channels and 12 output channels (1).

Turnover (2020)	1,600,000 €
% had a direct or indirect relationship with exportation	63%
Volume of sales that comes from the nuclear sector (2020)	45%
Staff	16 employees
Senior engineers (Engineers): Director, Lab Engineers & Sales Agent	7
Administrative staff / draftsmen	4
Other personnel	5

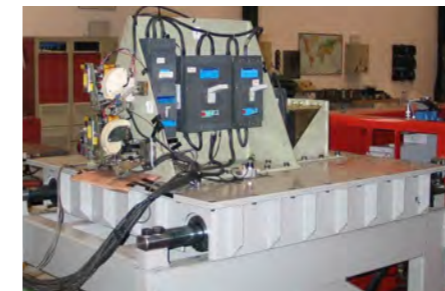

Others

- Accelerometer Calibration Set.
- Automatic accelerometer calibration system.
- 8.5-Digit Digital Multimeter.
- 6.5-Digit Digital Multimeter.
- 4.5-digit portable digital multimeter.
- Dc power supplies 1000W / 17A / 200V; 1500W / 10A / 150V; 1500W / 5A / 300V.

ACCREDITATIONS AND HOMOLOGATIONS

VIRLAB laboratory is accredited by the national (Spanish) accreditation entity (ENAC) according to the criteria laid down in the standard UNE-EN ISO / IEC 17025:2005. This accreditation is valid in all countries of the European Union, the rest of those represented in the European cooperation for Accreditation (EA) Organization and the signatories of the



Organization International cooperation for accreditation of laboratories (ILAC). At the same time, **VIRLAB** laboratory is approved by the NPP Spanish group.

TESTING STANDARDS

- CEI/IEC 60980: Recommended practices for seismic qualification of electrical equipment of the safety for nuclear generating station. [*]
- EN 60068-2-6: Environmental testing. Part 2-6: Tests. Test Fc: Vibration (sinusoidal). [*]
- 60068-2-27: Environmental testing. Part 2-27: Tests. Test Ea and guidance: shock. [*]
- EN 60068-2-64: Environmental testing. Part 2-64: Methods of test. Test Fh: Random vibration wide band and guide (random). [*]
- EN 60068-2-57: Environmental testing. Part 2-57: Tests. Test Ff: vibration. Method of accelerograms. [*]
- EN 60068-3-3: Environmental testing. Part 3: Guide. Methods of seismic tests applicable to the equipment. [*]
- IEEE 344: IEEE Standard for Seismic Qualification of Equipment for Nuclear Power Generating Stations. [*]
- CRT91.C.112.00: Tenue aux séismes des matériels. Dispositions génériques pour l'essai bi-axial par accélérogrammes de EDF.

- IEEE 382: IEEE Standard for Qualification of Safety-Related Actuators for Nuclear Power Generating Stations.
- KTA 2201.1: Design of Nuclear Power Plants against Seismic Events: Part 1: Principles.
- NT 100727 00 0111A: NOTE TECHNIQUE Projet ECS Méthodologie de Qualification sismique des équipements de Areva.
- STD7426E: METHODES D'ESSAIS SISMOUES DES EQUIPEMENTS de Areva.

(*) Accredited tests

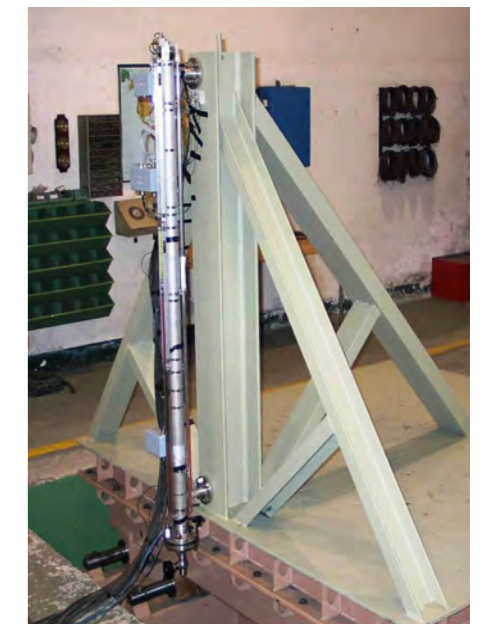
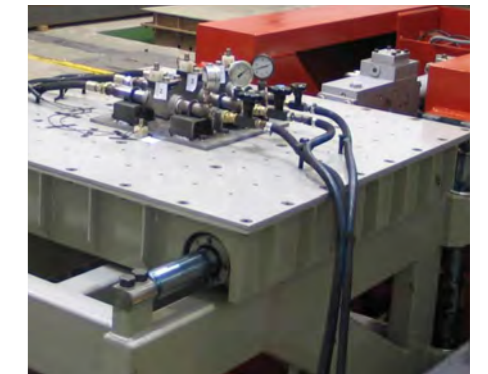



RADIOACTIVE WASTE MANAGEMENT AND DECOMMISSIONING

—

Enresa

86-87

—

Radioactive waste management and decommissioning of nuclear installations in Spain has acquired international prestige.

Headquarters
 C/ Emilio Vargas, 7
 28045, Madrid
 Tel.: +34 915 668 100
 E-mail: registro@enresa.es



The National Radwaste Company, ENRESA, is a public Company, created by Parliament in 1984 with state capital that plays an essential public service. Its mission is to collect, condition and store all the radwaste that is produced in Spain.

ENRESA is also in charge of dismantling the nuclear power plants whose activity has come to an end and of the environmental restoration of mines and uranium related installations, when so required by the authorities.

At present, ENRESA has a definitive radioactive waste storage sit for very low, low and average activity, in El Cabril located in the town of Hornachuelos in Cordoba.

The General Radioactive Waste Plan (PGRR) includes, as an objective for the management of Spent Fuel (CG) and High Level Waste (RAA), a Centralized Interim Storage Facility (ATC).

Regarding the dismantling projects, ENRESA is in charge of managing the Mestral Technological Centre, located in the old nuclear power plant of Vandellós I (Tarragona). Vandellós I is currently at the latent period, having completed its dismantling process to level 2. ENRESA is as well the Responsible Operator of the Jose Cabrera nuclear power plant in Guadalajara, during its dismantling process.

ENRESA is also involved, in coordination with Nuclenor, in the preliminary actions of the dismantling of Santa María de Garoña nuclear power plant, located in Burgos.



EL CABRIL STORAGE CENTRE

Ctra. A-447 Km 17,8 (dirección Fuenteovejuna-Cazalla de la Sierra)
 14740 Hornachuelos (Córdoba)
 Tel.: +34 957 575 100 Fax.: +34 957 575 130

2020 data

Total waste managed	2,375 m ³
Low and medium activity waste:	476 m ³
Very low activity waste	1,898 m ³
From hospitals, research centres and industry	97 m ³
From nuclear sites	2,277 m ³
Number of expeditions	266
ENRESA staff	114 employees

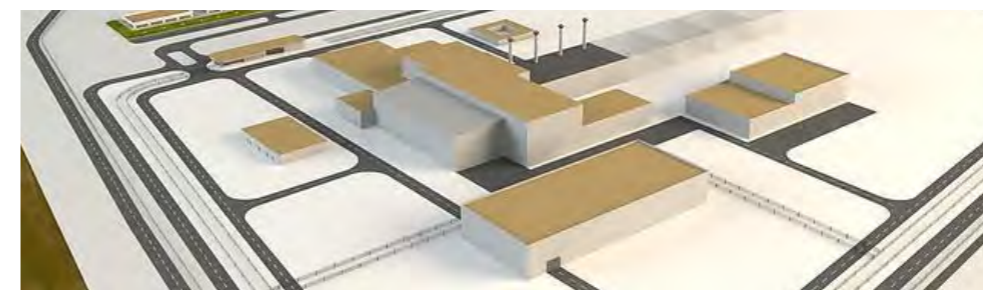

CENTRALISED TEMPORARY STORAGE SITE

Total waste that will be managed *	
Spent fuel	7,445 t
High activity vitrified waste	13 m ³
Special waste	6,050 m ³

* The total is included, also those generated in operation from the Centralized Interim Storage Facility (ATC) and Deep Geological Repository (AGP)



DISMANTLING

Nuclear Power Plant José Cabrera
 19118 Almonacid de Zorita (Guadalajara)
 Tel.: +34 625 661 452
 E-mail: cevisic@enresa.es

Mestral Technological Centre
 Ctra. N-340, Km 1123,7
 43890 L'Hospitalet de L'Infant (Tarragona)
 Tel.: +34 977 818 500 Fax.: +34 977 818 527
 E-mail: cevisva@enresa.es

Total waste that will be managed	Vandellós I	José Cabrera
Type of reactor and power	Graphite-Natural Uranium. 480 MWe	PWR. 160 MWe
Reactor shutdown	1989	2006
Tears of operation	17	38
Total materials managed	96,630 Tn	61,119 t
Conventional materials	84,894 Tn	10,937 t
Declassified materials	9,973 Tn	40,320 t
Radwaste	1,763 Tn	9,862 t
Dismantling period	1998-2003	2010-2022
Current dismantling status	Latency	Execution of the Dismantling and Closure Project
Average workforce during dismantling	323 employees	250 employees
ENRESA workforce	7 employees	14 employees

WEB DIRECTORY

—

A

Almaraz I and II Nuclear Power Plant
Amphos 21
Ascó Nuclear Power Plant

www.cnat.es
www.amphos21.com
www.anav.es

C

CEN Solutions
Cofrentes Nuclear Power Plant
Coapsa Control, S.L.

www.censolutions.es
www.cncofrentes.es
www.coapsa.com

E

EDP
Empresarios Agrupados
Endesa
Enresa
ENUSA, Industrias Avanzadas S.A., S.M.E.
Enwesa
Equipos Nucleares, S.A., S.M.E.

www.edpenergia.es
www.empresariosagrupados.es
www.endesa.com
www.enresa.es
www.enusa.es
www.enwesa.com
www.ensa.es

G

GD Energy Services
GE-Hitachi
Geotecnia y Cimientos
Grupo Eulen

www.gdes.com
www.nuclear.gepower.com
www.geocisa.com
www.eulen.com

I

Iberdrola
IDOM Consulting, Engineering, Architecture, S.A.U.

www.iberdrola.es
www.idom.com

K

Konecranes

www.konecranes.com

N

Naturgy
Newtesol
Nusim

www.naturgy.com
www.newtesol.com
www.nusim.com

P

Proinsa

www.proinsa.eulen.com

R

Ringo Válvulas, S.L.

www.ringospain.com

S

Santa Maria de Garoña Nuclear Power Plant
Spanish Nuclear Industry Forum

www.nuclenor.org
www.foronuclear.org

T

Taim Weser
Tecnatom
Trillo Nuclear Power Plant

www.taimweser.com
www.tecnatom.es
www.cnat.es

V

Vandellós II Nuclear Power Plant
VIRLAB, Expertise in Vibrations and shocks. Testing Laboratory

www.anav.es
www.virlab.es

W

Westinghouse Electric Spain

www.westinghousenuclear.com

